

SAFETY BRIEF

May, 2001

Volume 18, No. 4



Triodyne Inc.

Consulting Engineers & Scientists – Safety Philosophy & Technology
 5950 West Touhy Avenue Niles, IL 60714-4610 (847) 677-4730
 FAX: (847) 647-2047
 e-mail: info@triodyne.com
 www.triodyne.com

ANTI-HAIR SNARE POOL DRAIN COVER

By Ralph L. Barnett* and Peter J. Poczynok P. E.**



Figure 1 - Anti-Hair Snare Plus

ABSTRACT

A drain cover for swimming pools, spas and hot tubs has been designed which addresses eight hazards associated with conventional drain systems. This new drain cover, illustrated in Fig. 1, eliminates hair entanglement, child evisceration and finger entrapment as well as minimizing body entrapment. Furthermore, its design and construction provide effective countermeasures against vandalism, broken drain covers, missing drain covers and structural deterioration due to environmental antagonists. Additional features unrelated to safety include a universal fastening system which adapts the cover to all circular main drains available in the United States. Also the drain cover is an order of magnitude stronger than its competitors and has a safe flow rate that is 37% greater than its nearest competitor. This paper presents an anatomy of the product's development.

INTRODUCTION

Injuries and fatalities that occur during play are especially poignant because recreation is a pleasure directed nonnecessity. An automobile accident involving a child on the way to school is not the same as the evisceration of a youngster who is frolicking in a wading pool and must be fed intravenously for 20 hours a day for the rest of his life. Several years ago, after decades of work in aquatic safety, the authors were confronted with a product liability case involving a 16 year old high school girl who was entrapped on a twelve inch square drain cover while she was warming herself in a hot tub after her swim in a new

* Professor, Mechanical and Aerospace Engineering, Illinois Institute of Technology, Chicago and Chairman, Triodyne Inc., Niles, IL

** Senior Mechanical Engineer, Triodyne Inc., Niles, IL

This paper will be published in the Proceedings of the American Society of Mechanical Engineers' International Mechanical Engineering Congress and Exposition in November of 2001.

MECHANICAL ENGINEERING:

Triodyne Inc. (Est. 1969)

Officers
 Ralph L. Barnett
 Dolores Gildin
 S. Carl Uzgrigis, Ph.D.

Mechanical Engineering

Ralph L. Barnett
 Dennis B. Brickman
 Michael A. Dilich
 Christopher W. Ferrone
 Suzanne A. Glowiak
 John M. Goebelbecker
 Crispin Hales, Ph.D.
 Dror Kopernik
 Woodrow Nelson
 Cheryl A. Pattin, Ph.D.
 Peter J. Poczynok
 Audrone M. Stake, Ph.D.
 William G. Switalski
 George J. Trezek, Ph.D.
 S. Carl Uzgrigis, Ph.D.
 Raymond B. Wambaja
 James R. Wingfield, Ph.D.

Library Services

Marna S. Sanders
 Betty Bellows
 Donna Klick
 John Kristelli
 Florence Lasky
 Katherine Moyer
 Jackie Schwartz
 Joyce Styler

Information Products

Expert Transcript
 Center (ETC)
 Marna S. Sanders

Graphic Communications

Robert Koutry
 Charles D'Eccliss

Training and Editorial Services

Paula L. Barnett

Vehicle Laboratory

Charles Sinkovits
 Matthew J. Ulmenstine

Model Laboratory

2721 Allison Lane
 Wilmette, IL 60091-2101
 Bill Brown

Photographic Laboratory

7903 Beckwith Road
 Morton Grove, IL 60053
 Larry Good

Business Systems

Chris Ann Gonatas
 Cheryl Black
 Sandie Christiansen
 Rita Curtis
 Sandra Prieto

Facilities Management

Peter Warner

SAFETY RESEARCH:

Institute for Advanced Safety Studies

(Est. 1984)
 5950 West Touhy Avenue
 Niles, IL 60714-4610
 (847) 647-1101

Chairman

Ralph L. Barnett

Director of Operations

Paula L. Barnett

Information Services

Marna S. Sanders

Senior Science Advisor

Theodore Liber, Ph.D.

SAFETY PRODUCTS:

Triodyne Safety Systems, L.L.C.

(Est. 1998)
 5950 West Touhy Avenue
 Niles, IL 60714-4610
 (847) 677-4730
 FAX: (847) 647-2047

Officers/Directors

Ralph L. Barnett
 Paula L. Barnett
 Joel I. Barnett

President

Peter J. Poczynok

Vice President of Operations

Peter W. Warner

Senior Science Advisor

Theodore Liber, Ph.D.

Mechanical Engineering

Ralph L. Barnett
 Peter J. Poczynok

Aquatics Safety Consultant

Ronald M. Schroeder

ENVIRONMENTAL:

Triodyne Environmental Engineering, Inc.

(Est. 1989)
 5950 West Touhy Avenue
 Niles, IL 60714-4610
 (847) 677-4730
 FAX: (847) 647-2047

Officers

Ralph L. Barnett
 S. Carl Uzgrigis, Ph.D.

MANUFACTURING:

Alliance Tool & Manufacturing Inc.

(Est. 1945)
 91 East Wilcox Street
 Maywood, IL 60153-2397
 (773) 261-1712
 (708) 345-5444
 FAX: (708) 345-4004

Officers

S. Carl Uzgrigis, Ph.D.
 Ralph L. Barnett

General Manager

Ramesh Gandhi

Plant Manager

Bruno Stachon

Founders/Consultants

Joseph Gansacz
 Albert Kanikula

CONSTRUCTION:

Triodyne-Wangler Construction Company Inc.

(Est. 1993)
 5950 West Touhy Avenue
 Niles, IL 60714-4610
 (847) 647-8866
 FAX: (847) 647-0785

Officers/Directors/Managers

Joel I. Barnett
 William A. Wangler
 Joseph Wangler
 Ralph L. Barnett
 S. Carl Uzgrigis, Ph.D.

CONSTRUCTION PRODUCTS:

Triodyne-Wangler Construction Specialties, L.L.C.

(Est. 1999)
 5950 West Touhy Avenue
 Niles, IL 60714-4610
 (847) 647-8866
 FAX: (847) 647-0785

Officers

Joel I. Barnett
 William A. Wangler
 Joseph Wangler
 Ralph L. Barnett
 S. Carl Uzgrigis, Ph.D.

BUILDING MAINTENANCE:

Alliance Building Maintenance Corporation

(Est. 1999)
 5950 West Touhy Avenue
 Niles, IL 60714-4610
 (847) 647-1379
 FAX: (847) 647-0785

Officers

William A. Wangler
 Joseph Wangler
 David J. Smith
 Joel I. Barnett
 Ralph L. Barnett

CONSULTANTS:

Richard M. Bilof, Ph.D.

Electromagnetic Compatibility

Richard Gullickson

Industrial Hygiene/Safety/Chemistry

Beth A. Hamilton

Information Science

David W. Levinson, Ph.D.

Senior Metallurgical Advisor

Steven R. Schmid, Ph.D.

Food Processing Equipment

Diane Moshman

Chemical/Environmental
Engineering

Harry Smith

Electrical Engineering

Kim M. Mniszewski

Fire and Explosion

thirteen million dollar pool facility. Her buttocks sealed the drain and the associated ten horsepower pump instantly created a vacuum. Three certified pool officials, two fully dressed policemen, and her boyfriend jumped into the hot tub and struggled unsuccessfully against the one ton holding force.

This prom night tragedy could have been avoided by plumbing the two available spa drains into a common discharge pipe; this geometry precludes the formation of a vacuum if a single drain is blocked. A larger drain cover would have prevented the accident, however, the twelve inch square cover was and is regarded as a vacuum entrapment safeguard. A Suction Vacuum Release System (SVRS) might also have been incorporated into the drain system.

This case, coupled with the yearly pool deaths of 350 children below the age of five, provided the motivation for the engineering development of our drain cover product.

FAILURE MODES AND EFFECTS

Over a period of six months, eight failure modes were identified for pool and spa drain covers. Literature developed by the Consumer Product Safety Commission (CPSC) instantly identified hair entanglement, child evisceration and body vacuum entrapment. A survey of members of the pool industry yielded mechanical finger entrapment as a failure mode; the international pool literature confirmed this position. Additionally, the industry members raised the issue of drain cover strength, which is covered in part by the applicable ASME/ANSI consensus standard. Hearings of the Florida State Building Commission yielded concerns about the environmental degradation of drain covers as a cause of children's deaths. The forensic practice of Triodyne Inc. provided examples of missing drain covers and drain covers that were removed by teenagers seconds before the entrapment of a swim mate.

In non-safety related areas our industry survey yielded the following wish list for drain covers:

1. Third party certification by a nationally recognized testing laboratory.
2. "One size fits all" design for U.S. circular main drains.
3. High flow rate as measured with ASME/ANSI protocol.
4. Compatibility with automatic pool cleaners.
5. Availability of a support frame (mud ring) for resurfaced pools.
6. Color choices.
7. Minimum vortex formation.
8. Rectangular drain covers.
9. Wall mounted drain covers.

The following discussions of the eight known drain cover failure modes begins with hair *entanglement* because there is no other drain cover on the market that addresses this phenomenon. Indeed, it is not recognized in the ASME/ANSI A112.19.8M drain cover standard which treats

only hair *entrapment*. This is caused by hydrodynamic flow which creates a drag force on hair that passes through the grating. The standard restricts the flow to a level that places no more than five pounds of force on a specific hair sample. No known case of drowning has been attributed to hair entrapment. Hair *entanglement*, on the other hand, has been found by the CPSC to be the cause of every hair related fatality.

HAIR ENTANGLEMENT

When hair strands are drawn through drain gratings hair entanglement may follow by the knotting or wrapping mechanisms illustrated in Figures 2a and 2b respectively. Both mechanisms are sufficiently aggressive that a bather may be trapped even in the face of heroic intervention. Four concepts are presented that address hair entanglement.

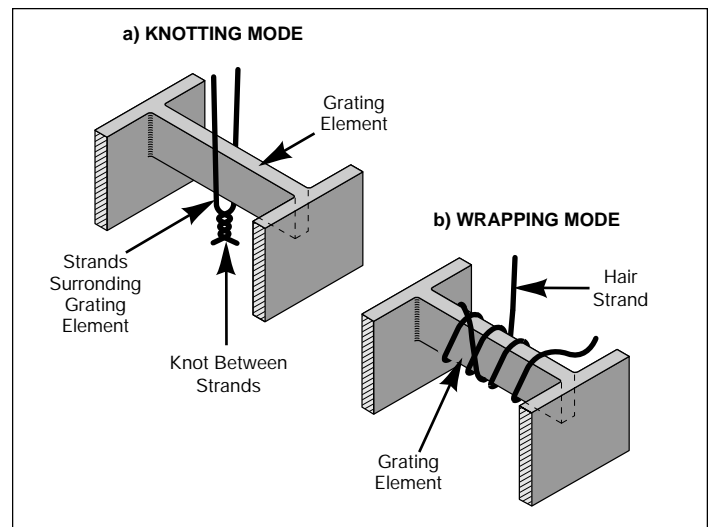
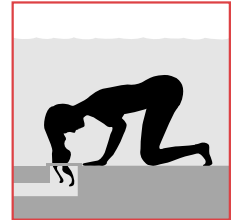

Figure 2 - Hair Entanglement Models

Collimated Gratings

By extending the vertical dimensions of most conventional drain gratings, one obtains a series of prismatic tubes such as shown in Fig. 3. The resulting collimated gratings provide two unique countermeasures against the danger of hair entanglement.

The most important safety feature of collimated gratings is associated with "critical length" as defined in Fig. 4. It is observed that hair strands shorter than the critical length L cannot lasso a grating element by knotting. Furthermore, the wraparound entanglement mode can never occur. Clearly, as L gets larger the percentage of the population who will enjoy total protection against hair entanglement increases. Main drains are currently available to accommodate a critical length of 12 inches.

A second safety property of collimated gratings comes into play when hair strands are longer than L . Here, hairs from

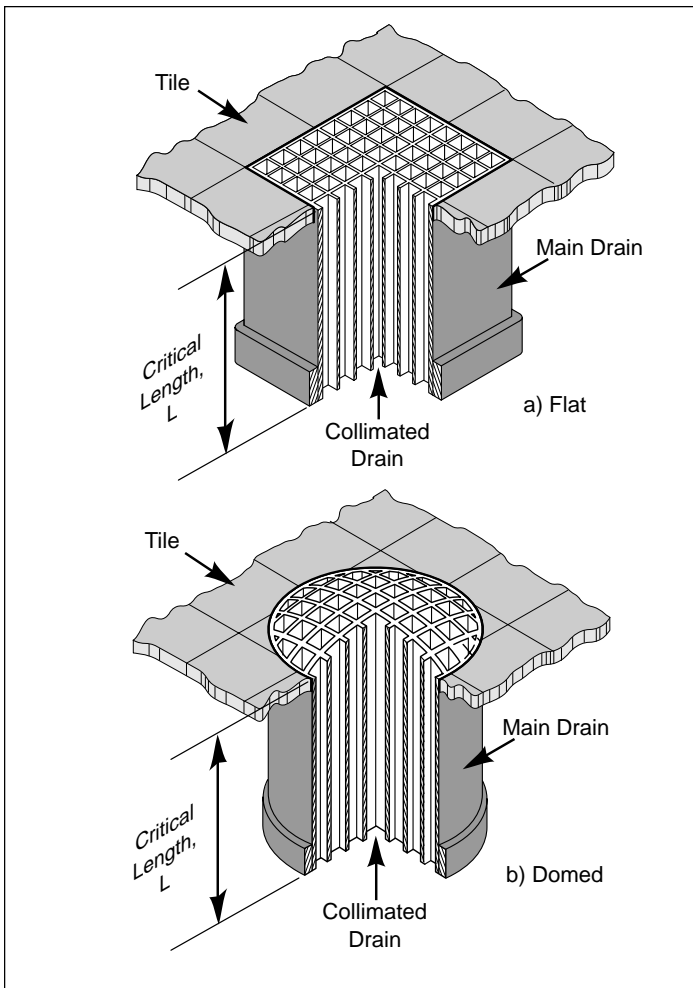

Figure 3 - Collimated Gratings

neighboring grating tubes may intertwine. Figure 5 suggests that turbulent flow on the downstream side of gratings has a greater tendency to form knots in hair strands than laminar flow. We note that for circular tubes of diameter D , the ratio D/L may always be designed small enough to preclude turbulence. The collimated grating was patented November 9, 1999 by John Nelson. (Pat. 5,978,981). The domed collimated drain shown in Figure 3b is the subject of a design patent by Ralph L. Barnett (D410,073, May 18, 1999).

Liftable Gratings

Unsecured gratings, such as that shown in Fig. 6, will not hold down a person whose hair has become ensnared. Most conventional gratings are secured to pool surfaces or main drains using fastening systems that cannot be breached by human strength. It is, of course, a simple matter to design detented gratings that will “pop up” or break away at modest force levels. One such drain cover is currently being marketed under the “Primus” name.

It should be noted that liftable gratings are often counterindicated by overall safety considerations. Most drainage systems require secured gratings to protect against the hazards of tripping, entrapment, and disembowelment.

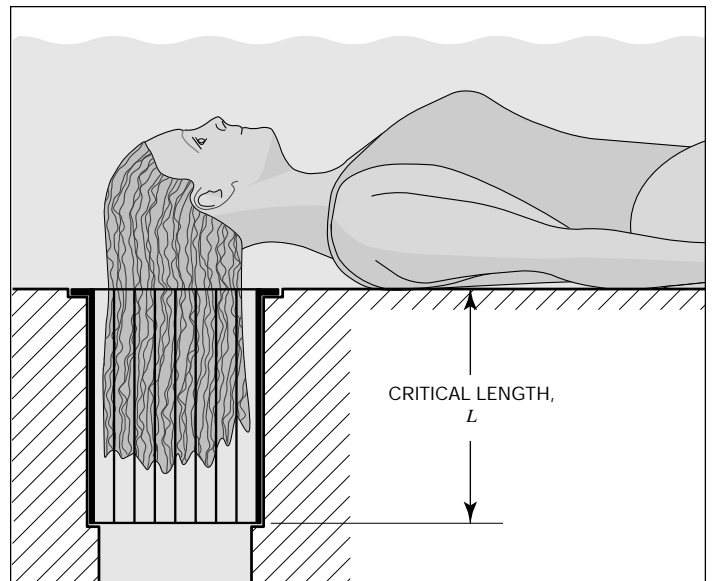

Figure 4 - Critical Length

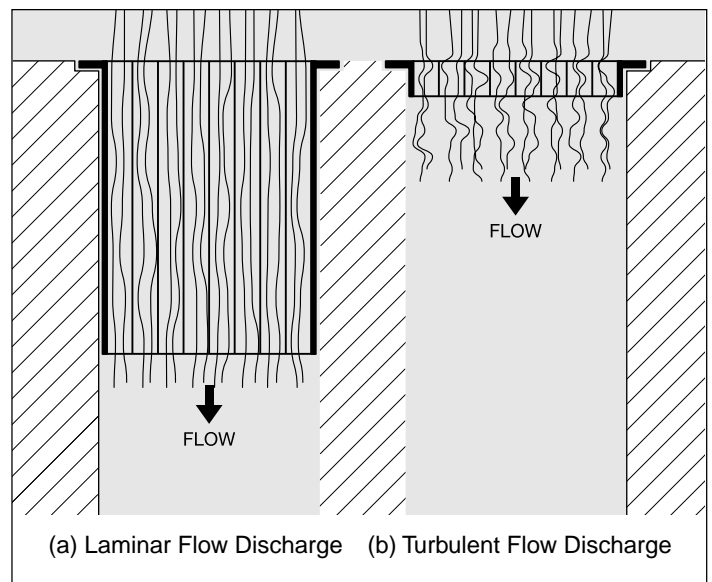

Figure 5 - Downstream Laminar Flow

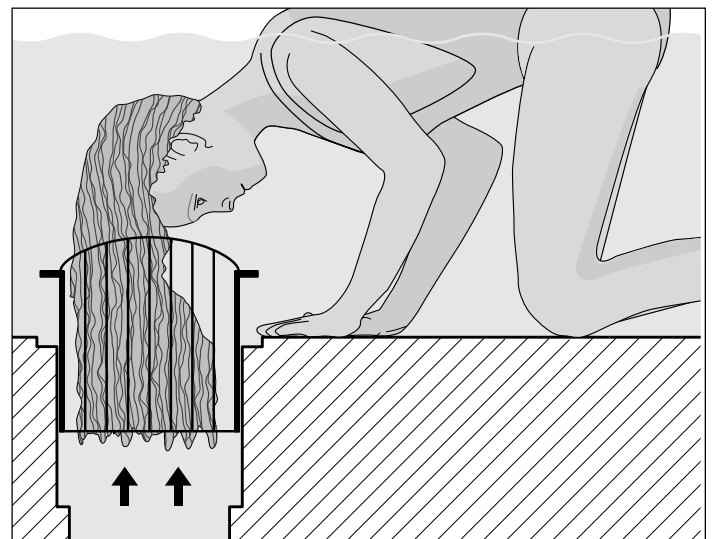

Figure 6 - Liftable Drain Cover

Cutting Edge Grating Elements

Disengagement of entangled hair from drain gratings is restricted by forces developed at the bottom surface of the grating elements. If these surfaces are fashioned into cutting edges as shown in Figure 7, hair strands may be severed to release a bather. The edges may incorporate some of the modern “stay sharp” profiles. Grating materials must be selected to sustain the integrity of the cutting edges in the face of harsh pool and hot tub chemistry. Furthermore, the grating apertures must be designed to preclude finger contact with the sharp edges at the bottom of the grating.

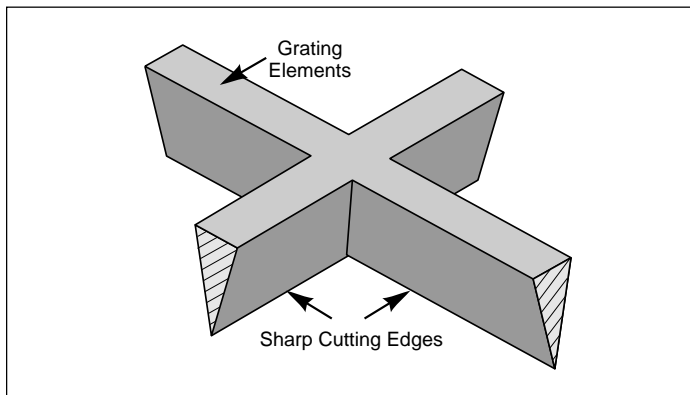

Figure 7 - Intersecting Sharp Edge Grating Elements

Cantilevered Grating Elements

Conventional grating elements, such as shown in Fig. 2, consist of horizontal prismatic beams supported at both ends. As indicated in Fig. 2a, no escape geometry is provided in the knotting mode. Furthermore, a single wrap around a straight element can entrap a strand of hair. On the other hand, cantilevered elements always provide an escape geometry as illustrated in Fig. 8a. Indeed, the steep angle on the bottom surface of the element leads to shedding of the hair lasso. The effect of the tapered cantilever profile illustrated in Fig. 8b also precludes wrapping entanglement by the same shedding mechanism.

Because the cantilevered grating can be retrofitted onto existing main drains and will release hair of any length, this concept was chosen for the Anti-Hair Snare Plus™ design. The final product is shown in Fig. 1; its self shedding feature is illustrated in Figs. 9a and 9b. Because the Anti-Hair Snare Plus™ is essentially a domed comb, a tangle may be disengaged by sliding it into the drain cover's center hole as illustrated in Fig. 9c. These concepts were patented by Ralph L. Barnett in July 18, 2000 (Pat. 6,088,842). Furthermore, the form of the Anti-Hair Snare Plus™ was patented by Ralph L. Barnett and Peter J. Poczynok on April 3, 2001 (US D439,957).

CHILD EVISCERATION

If a drain is sealed, even the smallest circulation pump will eventually pull a near-vacuum. With normal pool/spa pumps, children sitting on a

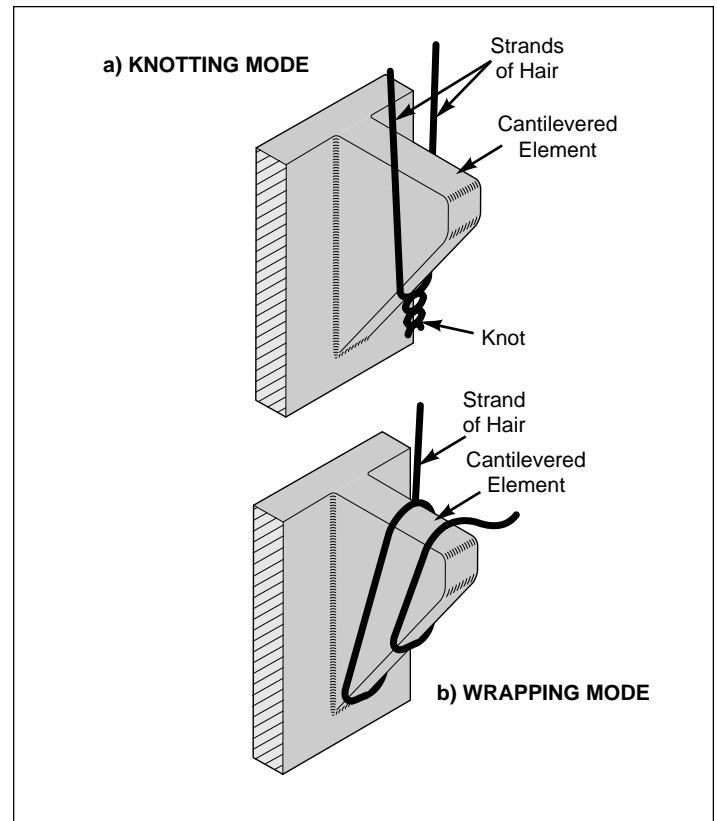

Figure 8 - Cantilevered Grating Elements

conventional flat drain cover may be disemboweled in a fraction of a second if their buttocks seal the drain. There is a class of domed drain gratings called anti-vortex covers, that have circumvented this danger. The Anti-Hair Snare Plus™ incorporates both a domed geometry and a hi-lo step profile created by alternating high long arms and low short arms as illustrated in Fig. 1; child evisceration is eliminated.

BODY VACUUM ENTRAPMENT

Vacuum entrapment will occur if every aperture in a drain cover is blocked by a portion of a bather's body during pumping. This is the usual mechanism that causes evisceration in children. In most cases a circular grating will hold a victim to the drain with about 600 pounds. Another method of entrapment occurs when the body envelops the drain cover by forming a seal circle outside of the cover. For example, the back or stomach may form a circular seal with the pool surface enclosing an area whose expanse is much greater than the plan area of the cover. The hold down force associated with this mechanism is not currently understood.

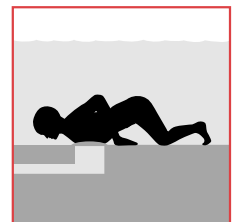

Figure 10 indicates that more aggressive geometries are more difficult to seal against the stomach. The pecking order shown in Fig. 10 was established from a balloon test conducted with the apparatus depicted schematically in Fig. 11.

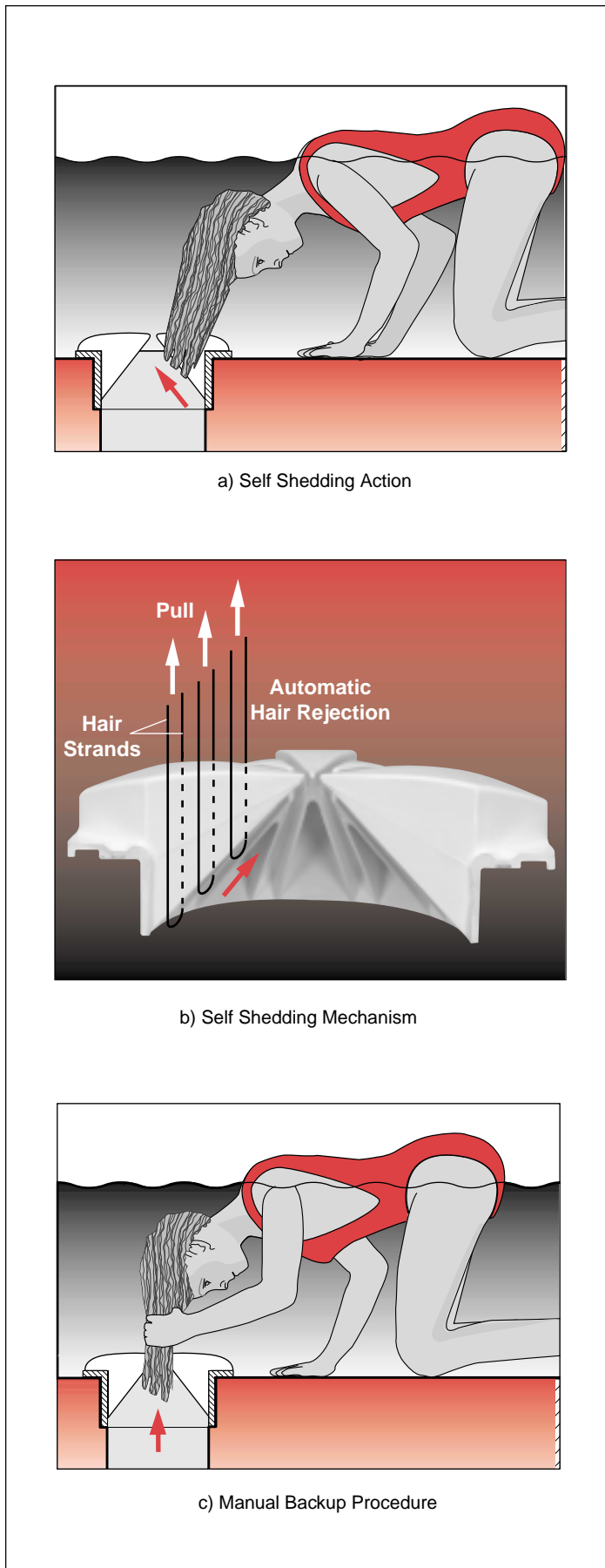

Figure 9 - Anti-Hair Entanglement Characteristics

Pairs of drain cover candidates were mounted coaxially between two parallel plastic plates with dimensions of 3 ft. x 3 ft. x 3/4 in. The inward facing drain cover pairs were contacted by an air filled balloon located symmetrically between the drain covers. The air pressure was gradually increased until the first drain cover was enveloped by a surrounding seal.

When compared to the available circular anti-vortex covers, the Anti-Hair Snare Plus™ was superior; its effective seal circle had the greatest diameter. This is because of the long arms shown in Fig. 1; there is a 3/4 in. step at the outside diameter of the cover, in sharp contrast to the gradual rise at the base section of the short arms. This step precludes sealing near the periphery of the cover.

It is important to understand that the Anti-Hair Snare Plus™ can only minimize entrapment; there are people that are sufficiently endowed to enfold the drain cover.

MECHANICAL FINGER ENTRAPMENT



Fingers are not circular in cross section. If they are inserted into non-circular apertures and twisted, a mechanical locking may take place which can entrap a bather. For circular apertures, inserted fingers may be trapped or experience delayed removal because of a reverse locking property. This is analogous to a ring going onto one's finger more easily than it comes off.

If the knuckles are prevented from passing through the bottom surface of the drain cover, twist locking and reverse locking of the fingers is precluded. Based on anthropometric studies [1, 2] of children reported by the Society of Automotive Engineers (SAE), the index and middle fingers of five percentile two year old males and females cannot pass through 8 mm circular apertures. Furthermore, the little finger of five percentile females older than 37 months will be protected by the application of the 8mm rule. It is not expected that 3 or 4 year old children will be playing with drain covers in deep water.

An 8 mm rule has been proposed as an European standard covering the maximum safe apertures in drain covers. Specifically,

Draft prEN 13451-1 (Dec. 1998)

4.8.3 Entrapment of Fingers - Equipment shall be constructed so that any opening does not create finger entrapment hazards.

1) 8mm finger rod shall not pass through the minimum cross-section of the opening and the profile of the opening shall be such that the rod cannot be locked in any position...

The maximum apertures in the Anti-Hair Snare Plus™ will prevent penetration of an 8 mm diameter rod. They are all less than 8 mm in their smallest dimension.

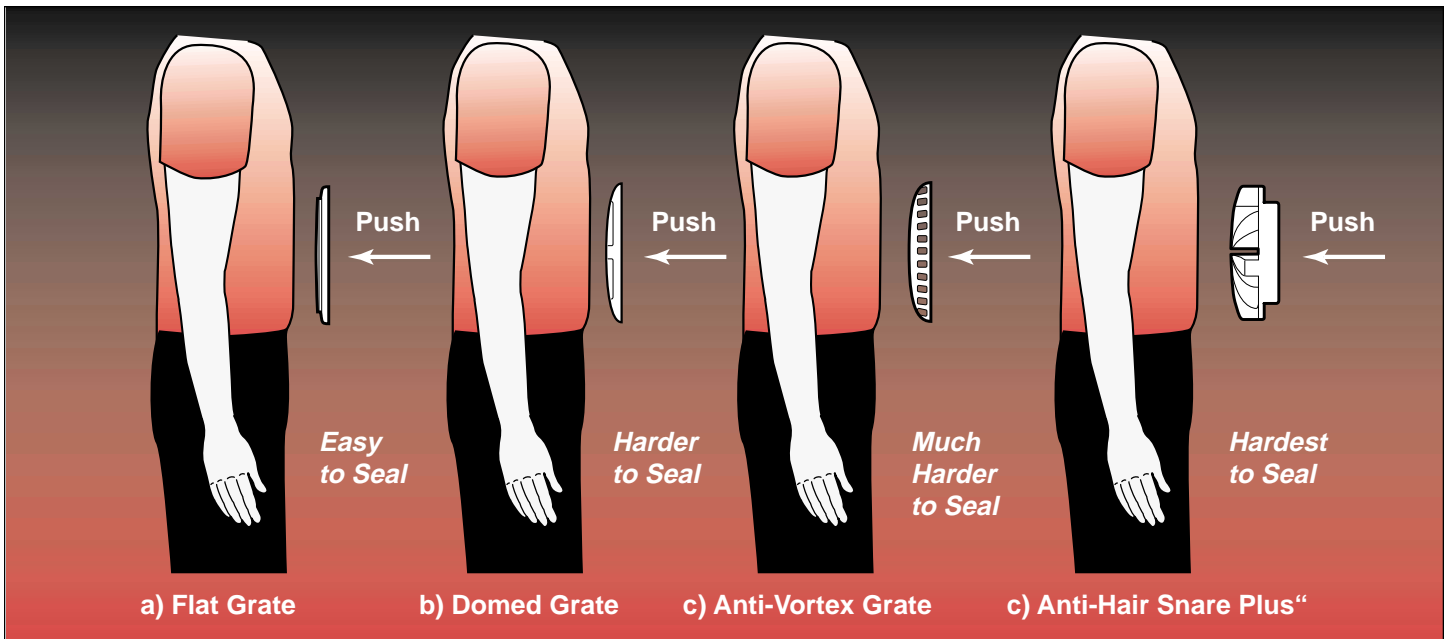

Figure 10 - Ranking Drain Cover - Sealing Effectiveness

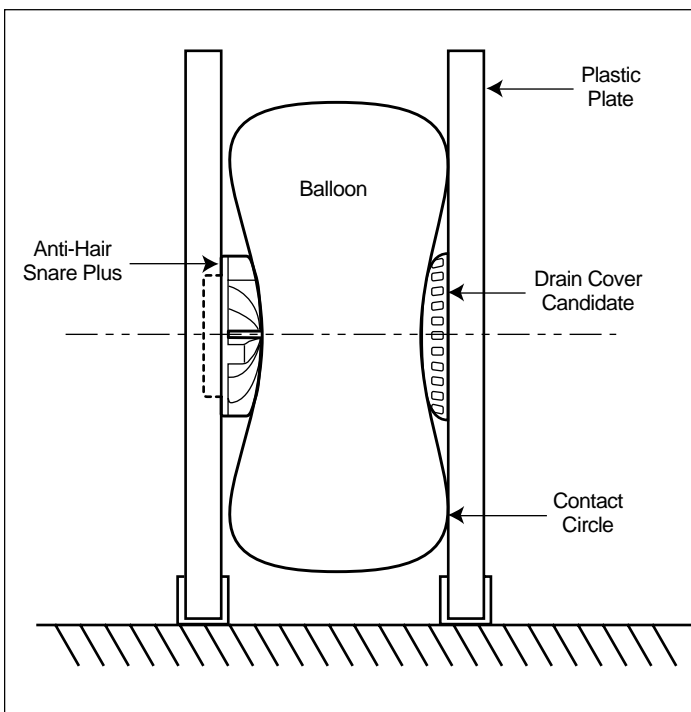
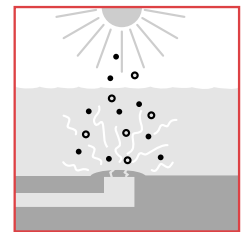

Figure 11 - Balloon Test For Comparative Sealing

ence or power grip may be formed. This type of grip would enable teenagers to develop lifting forces in the neighborhood of 100 pounds. There are drain covers and fastening systems that cannot resist such loads. If the apertures in the drain cover are too small to allow an interference grip to form around the cover elements, potential lifting forces are de minimis and the problem of “grip it and rip it” disappears. Because the Anti-Hair Snare Plus™ was designed to the 8 mm rule, only a friction grip on the cover is possible.

ENVIRONMENTAL DEGRADATION

Drain covers used in outdoor applications are exposed to ultraviolet radiation that weakens most polymers and makes them increasingly brittle. In addition, the grating materials are exposed to chlorine and other aggressive pool chemicals. The standard for suction fittings, ASME/ANSI A112.19.8M - 1987, deals with these environmental issues with a one sentence admonition:



“When plastic materials are used, UV inhibitors shall be added to the polymer mixture.”

Testimony of homeowners before the Florida Building Commission included cases where weakened gratings partially fractured subjecting children to body entrapment and trauma from exposed sharp fractured surfaces.

The material recommended for the Anti-Hair Snare Plus™ by our molders was polyvinyl chloride (PVC). Our PVC supplier, Prime PVC, formulated a polymer with a high concentration of titanium dioxide for long term stability in a

GRIP IT AND RIP IT

It has been firmly established in the pool industry that pool drain covers must maintain their structural integrity and must remain secured to the main drain. Otherwise, bathers may entrap their arms and legs in the drain. If portions of the covers can be penetrated by fingers far enough to wrap around the cover elements, an interfer-

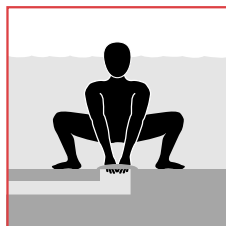

UV environment. The resulting material was certified by NSF International to meet ANSI/NSF Standard 50 which covers materials intended to be in contact with swimming pool or spa/hot tub water.

BROKEN DRAIN COVERS

The arch design of Anti-Hair Snare Plus™ closes up the central apertures under the symmetrical loadings specified by ASME/ANSI A112.19.8M. Depending on the main drain used, 2600 to 4700 pounds are required to cause a 2 in. diameter tup with a 2-1/2 in. radius nose to penetrate the subject design. The ultimate failure is ductile with no disintegration. There is no foreseeable loading that will compromise this design.



The strength testing called for in the standard was performed by NSF International as part of their “third party certification” program. An “on product” warning sign is molded into the flange surrounding the Anti-Hair Snare Plus™;

 Danger
Replace This Part If
Broken or Damaged

This admonition is repeated in the product manual.

MISSING DRAIN COVERS

To warn the installer of the subject drain cover to keep the appliance *in situ*, there is an “on product” label molded into the flange,

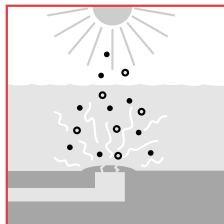

 Danger
Keep Secured With
Stainless Steel Screws

Furthermore, there is another admonition to “read and follow instructions” that is, once again, molded into the plastic flange. The manual deals with the “missing drain cover” problem in sections concerning safety and installation. An extensive screw chart is provided to aid the installer in selecting the proper fasteners for every main drain appliance.

The system designed to minimize missing drain covers includes the exceptional cover strength, the high environmental resistance, the freedom from “grip it and rip it” scenarios, and an information program involving admonitions on the shipping box (pizza type), on the product, and in the manual.

NON-SAFETY FEATURES

One cannot sell safety without first admitting that danger exists. This is viewed by the pool/spa industry as “negative sell” [3]. Indeed, most industries have faced this dilemma. When there was no solution for the eight failure modes, salesmen were reluctant to describe them to potential customers. On the other hand, today finds the enemy vanquished. Selling safety is a positive experience that shows the pool/spa industry in a positive light.

To help the industry offset the effects of “negative sell”, our design direction was dictated by the “wish list” revealed by our industry survey:

- Third party certification by a nationally recognized testing laboratory - The Anti Hair Snare Plus™ is the first drain cover to achieve NSF International certification to both ASME/ANSI A112.19.8M and ANSI/NSF Standard 50. It is anticipated that an increasing number of state and local regulatory officials will demand such certification.
- High Flow Rate - The drain cover standards provide a protocol for determining the “acceptable flow rate.” NSF measured this for the subject drain cover at 109.6 GPM; this is 37% higher than the next highest candidate.
- Pool Cleaner Friendly - Automatic vacuum type pool cleaners (pickers) can operate on the bottom and side surfaces of a pool. These vacuum cleaners use approximately 5% of their vacuum to hug the operating surface. When pickers encounter an anti-vortex drain cover, such as that depicted in Fig. 10c, they often hang-up when they mount the cover and vacuum lock onto the top surface which is impervious and almost flat. The open configuration of the Anti-Hair Snare Plus™ does not allow a vacuum to form; the pickers climb over unimpeded.
- Universal Fit - Using a series of partially formed screw holes, the three mounting methods depicted in Fig. 12 allow, with one exception, every round U.S. main drain to be retrofitted with the Anti-Hair Snare Plus™.

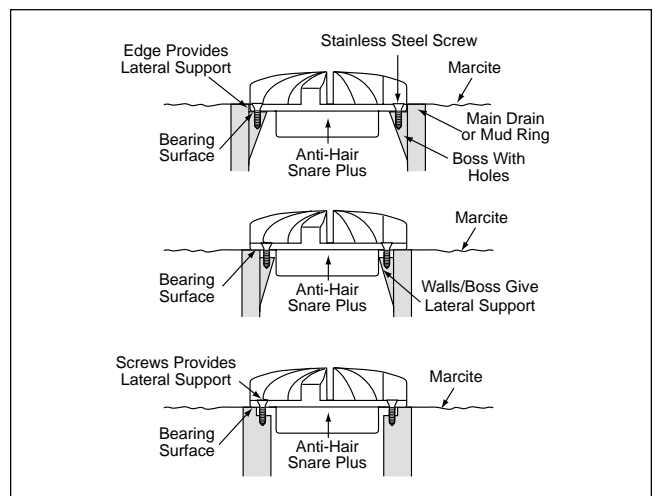

Figure 12 - Mounting Methods

- Support Frame (Mud Ring) - When pools are resurfaced, a floating frame is “mudded in” to accommodate a drain cover. A companion frame was designed for the Anti-Hair Snare Plus™ that can be turned upside down to also act as an adaptor ring for the one main drain that eluded our direct retrofit. The frame is shown in Fig. 13a. Its use as a mud ring is depicted in Fig. 13b and its application as an adapter for a Sta-Rite main drain is illustrated in Fig. 13c.

CONCLUSIONS

Vigilant supervision is an extremely effective accident counter-measure for swimming ineptitude, diving, horseplay, drunkenness, run and fall medical emergencies, and assault and battery. Unfortunately, supervision together with heroic intervention are impotent in the face of pool and spa drain hazards. Evisceration occurs in a fraction of a second. Four to six hundred pounds of suction force must be overcome to lift an entrapment victim from a circular drain. Parents are not strong enough to scalp a child whose hair is entangled in a drain cover. Collectively, the eight failure modes are truly insidious since the death struggle is obscured and silent.

The drain covers currently available in the U.S. have not been designed by engineers. They do not “hold paramount the public safety, health and welfare...” Most do not comply with their industry standard and only a few have a manual, usually a single page. The ASME/ANSI standard does not reflect the safety innovations pioneered by industry practitioners including some that enjoy widespread use, e.g., the dual drains in California. The Anti-Hair Snare Plus™ is an engineered product that addresses all of the known drain cover safety problems and which is compatible with other safety intervention concepts that form the “layers of protection” advocated by pool/spa professionals.

REFERENCES

[1] Anthropometry of Infants, Children, and Youths to Age 18 for Product Safety Design, SP-450, SAE, 1977.
 [2] Anthropometry of Infants, Children, SP-394, SAE, 1975.
 [3] Steinike, Jill, “Mandating Safety,” Aqua Magazine, March 2001, p. 41.

SAFETY BRIEF

May, 2001 – Volume 18, No. 4
 Editor: Paula L. Barnett
 Illustrated and Produced by
 Triodyne Graphic Communication

Copyright © American Society of Mechanical Engineers (ASME). All Rights Reserved. No portion of this publication may be reproduced by any process without written permission of ASME. Questions pertaining to this publication should be directed to Triodyne, Inc., 5950 West Touhy Avenue, Niles, IL 60714-4610 (847) 677-4730. Direct all inquiries to: *Library Services*.

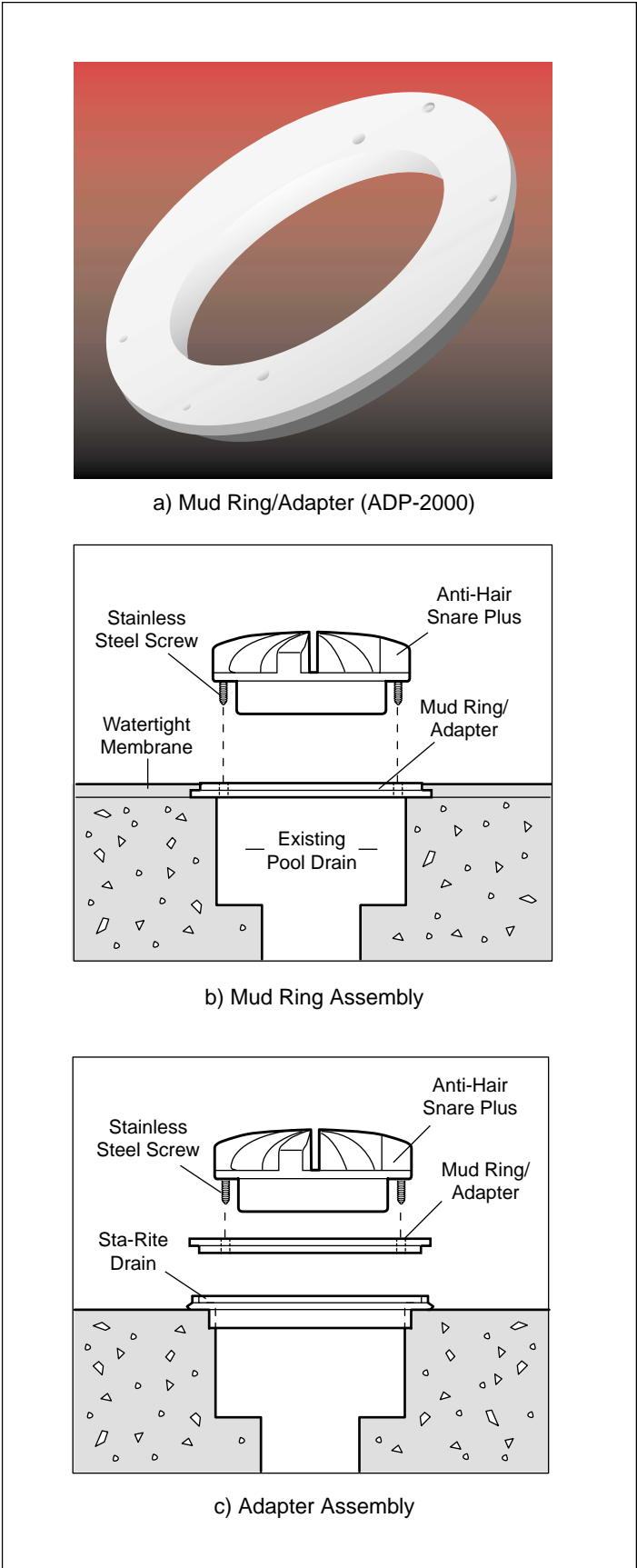

Figure 13 - Support Frame and Adapter for the Anti-Hair Snare Plus™