

Fountain Fixture Installation Instructions

(For Fountain or Pond use ONLY)

IMPORTANT SAFETY INSTRUCTIONS
READ AND FOLLOW ALL INSTRUCTIONS
SAVE THESE INSTRUCTIONS



Small Fountain Fixture

(P/N 560001)

is to be used ONLY with
Pentair Pool Products

Luminaire P/N's:

6400XX, 771XXXXX,
773XXXXX, 781XXXXX,
785XXXXX, 786XXXXX,
and 7878XXXX.



Small Fountain Fixture (P/N 560001)



Large Fountain Fixture (P/N 560000)

Large Fountain Fixture

(P/N 560000)

is to be used ONLY with
Pentair Pool Products

Luminaire P/N's:

783XXXXX, 784XXXXX,
788XXXXX, and
789XXXXX.

DANGER



Risk of Electrical Shock or Electrocutation.

This product must be installed by a licensed or certified electrician in accordance with the National Electrical Code and all applicable local codes and ordinances. Improper installation will create an electrical hazard which could result in death or serious injury to installer, or others due to electrical shock, and may also cause damage to property.

WARNING



Risk of Electrical Shock or Electrocutation.

Do **NOT** use in a swimming pool, spa or other body of water involving immersed person use. **USE ONLY** with a luminaire marked as a "submersible luminaire". A luminaire marked as a swimming pool or spa luminaire must also be marked 'submersible luminaire' to be used with this fountain fixture.

WARNING

Before installing this product, read and follow all warning notices and instructions accompanying this product. Failure to follow safety warnings and instructions can result in severe injury, death, or property damage. Call (800) 831-7133 for additional free copies of these instructions.

Important Notice



Attention Installer.

This manual contains important information about the installation, operation and safe use of this product. This information should be given to the owner/operator of this equipment.

Pentair Pool Products

1620 Hawkins Ave., Sanford, NC 27330 • (919) 774-4151

10951 West Los Angeles Ave., Moorpark, CA 93021 • (805) 523-2400

Pentair
Pool Products®
Because reliability matters most

Section I. Installing Fountain Light Fixture

A. Preparatory steps which must be completed by the electrician before the light fixture is installed.

1. Verify that the fountain meets the requirements of the current National Electrical Code and all local codes and ordinances. A licensed or certified electrician must install the electrical system to meet or exceed those requirements before the underwater light is installed.
2. Verify that the lighting circuit has a Ground Fault Circuit Interrupter (GFCI) for line voltage models and has an appropriately rated circuit breaker.
3. Ensure that the fountain has enough water depth for the entire fixture to be completely submerged at least 2 inches below the minimum operating water level.
4. Use only Pentair Pool Products lights with this Fountain Fixture to ensure proper bonding and grounding.

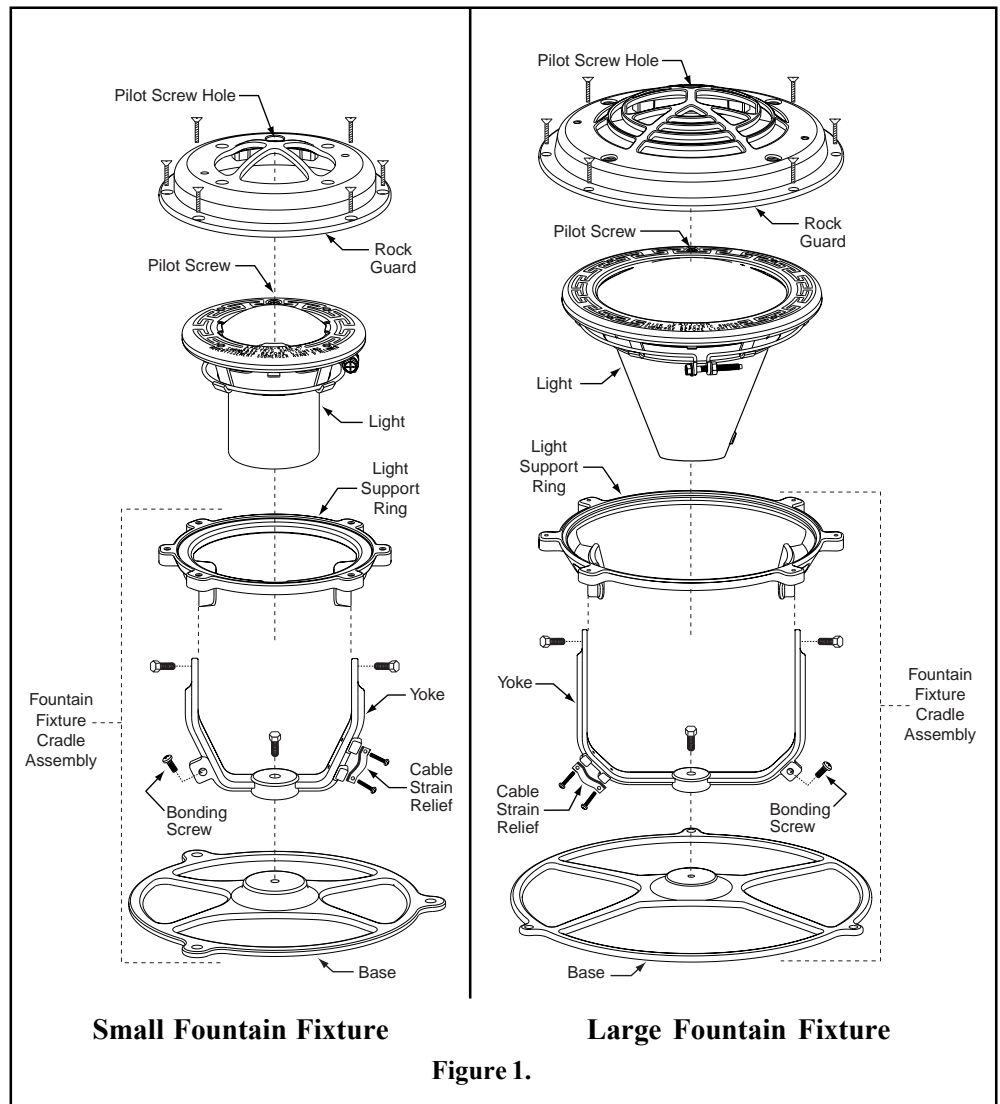

B. Steps to perform after the electrical system requirements are met:

1. Assemble the Fountain Fixture cradle assembly as shown in Figure 1.
2. Position the light on the Fountain Fixture cradle assembly with the pilot screw in the 12 o'clock position.
3. Assemble the rock guard to the fixture with the pilot screw hole aligned with the pilot screw of the light.
4. Feed the cord through conduit to the Junction Box, (*check Local Codes for Junction Box installation requirements*). Ensure that the length of exposed cord in the fountain is no more than 10 feet (3 m.), see Figure 2.
5. Cut the cord at the Junction Box, leaving at least 6 inches of cord to make connections.
6. Strip 6 inches of the outer cord jacket to expose the three insulated wires – be careful not to damage the insulation on the three inner wires.
7. Connect all three wires to the corresponding circuit wires in the Junction Box and secure the Junction Box cover in place.
8. Position the Fountain Fixture as desired in the fountain.
9. Use the strain relief in the Fountain Fixture to secure the light cable.

10. If required by Local Ordinances, use the bonding lug in the Fountain Fixture to ensure proper bonding of light.

⚠ WARNING

Never operate this underwater light for more than 10 seconds unless it is totally submerged in water. Without total submersion, the light assembly will get extremely hot, which may result in serious burns or in breakage of the lamp or lens. This may result in serious injury to pool/spa users, installers, or bystanders, or in damage to property.

- 11. Fill the fountain until the light is completely submerged in water before operating it for more than 10 seconds. Entire fixture must be at least 2 inches below minimum operating water level.
- 12. Turn on main switch or circuit breaker, as well as the switch that operates the light itself, to check for proper operation. Refer to Operating Instructions.

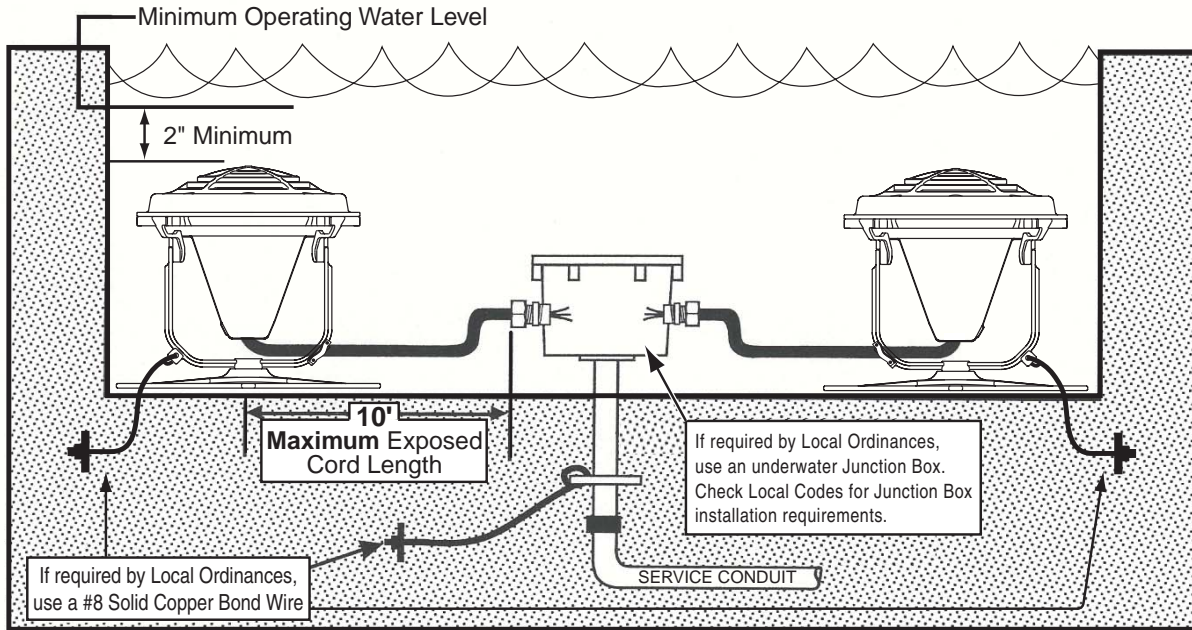
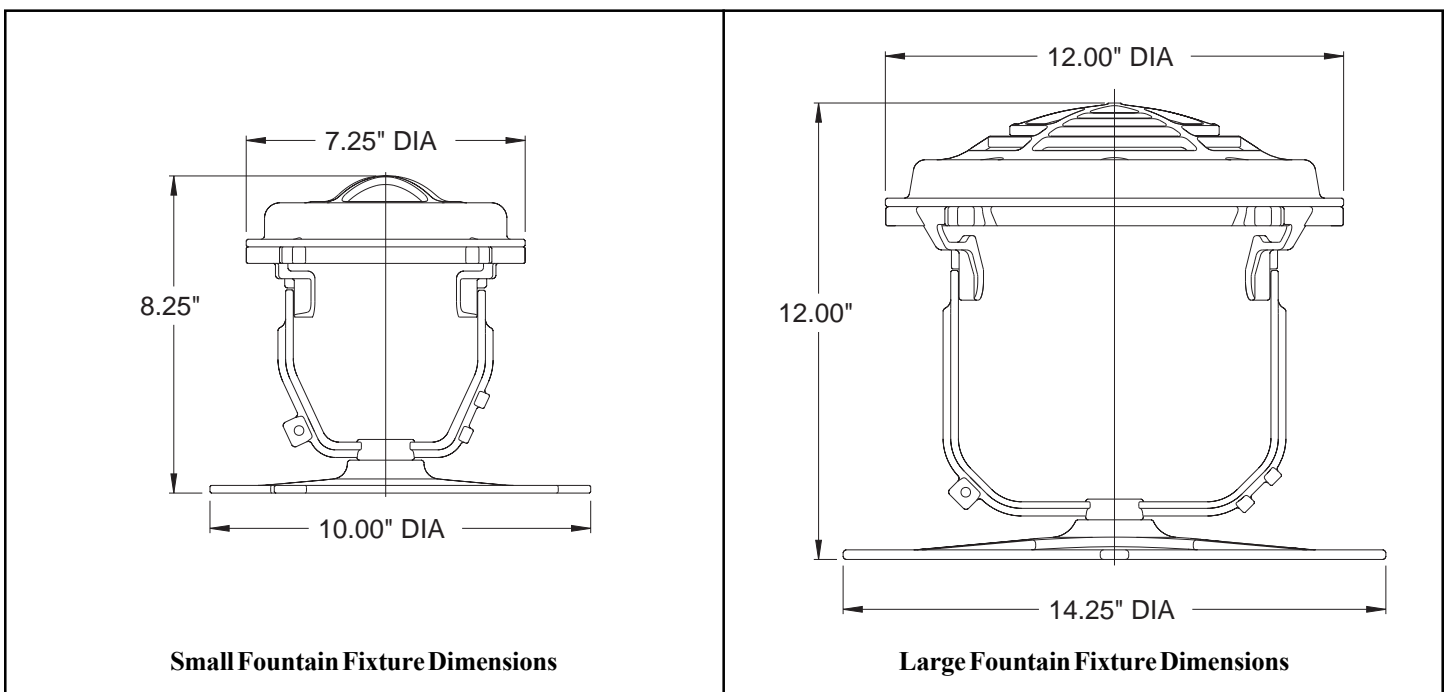

Figure 2.



Section II. Technical Data

A. Replacement Parts

Item No.	P/N	Description
1	570000	Rock Guard - Large Fountain
2	570005	Rock Guard - Small Fountain
3	570004	Fountain Fixture Screw Kit

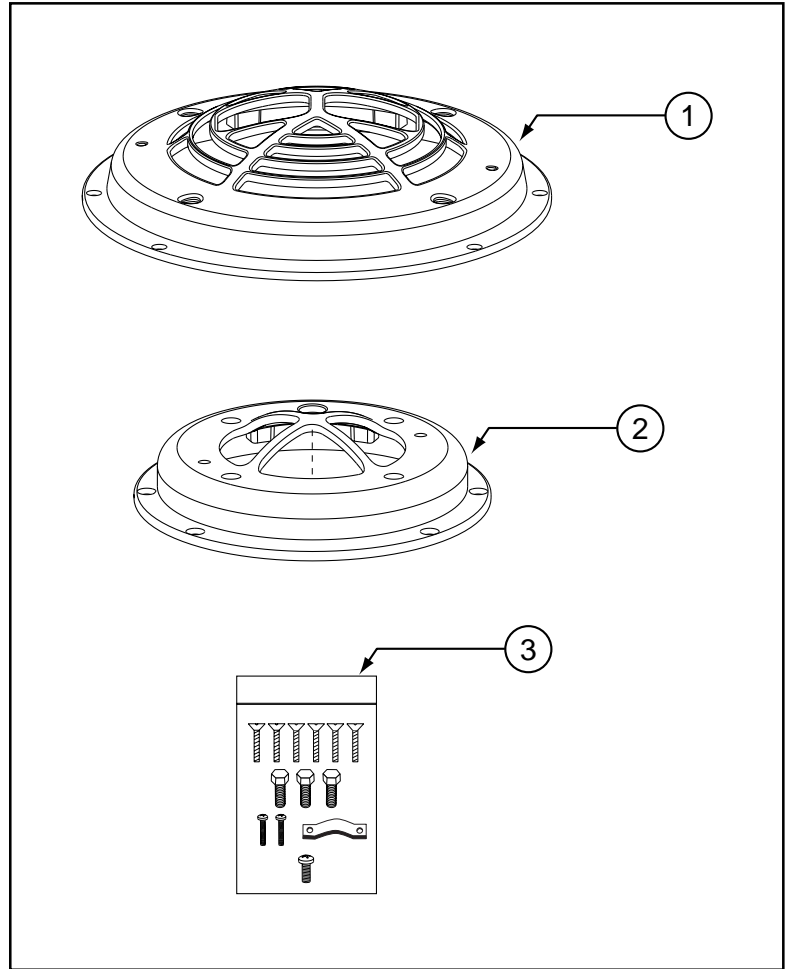

SAVE THESE INSTRUCTIONS.

Pentair Pool Products

1620 Hawkins Ave., Sanford, NC 27330 • (919) 774-4151
10951 West Los Angeles Ave., Moorpark, CA 93021 • (805) 523-2400

