

Jandy® Pumps

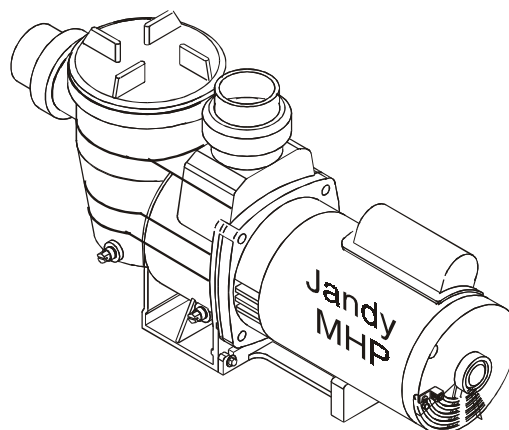
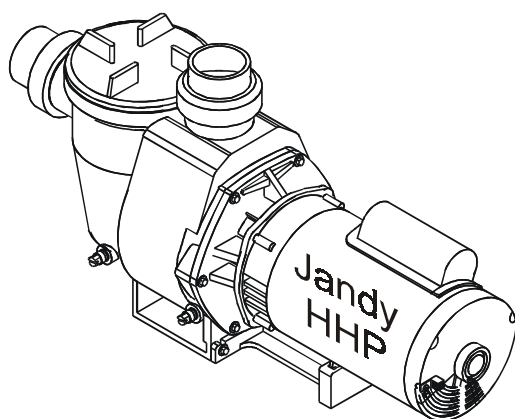

Installation and Operation Manual HHP, MHP & MHPU Jandy™ Pumps

WARNING

FOR YOUR SAFETY - This product must be installed and serviced by authorized personnel, qualified in pool/spa installation. Improper installation and/or operation can create an electrical hazard which can cause serious injury, property damage, or death. Improper installation and/or operation will void the warranty.



ATTENTION INSTALLER:

This manual contains important information about the installation, operation and safe use of this product. This information should be given to the owner/operator of this equipment.

TABLE OF CONTENTS

SECTION 1

Safety Information

- 1A. Safety Instructions..... 4

SECTION 2

General Information

- 2A. Introduction..... 5
2B. Description..... 5

SECTION 3

Preparation and Location

- 3A. Pump Preparation..... 5
3B. Pump Location..... 5

SECTION 4

Piping Design and Installation

- 4A. Size of Suction Pipe..... 6
4B. Size of Discharge Pipe..... 6
4C. Installation Tips..... 6

SECTION 5

Electrical Verification and Installation

- 5A. Checking for Correct Voltage..... 7
5B. Bonding Motor to Pool Structure..... 7
5C. Electrical Wiring..... 7

SECTION 6

Start-up

- 6A. Pump Start-up..... 8

SECTION 7

Use and Maintenance

- 7A. General Maintenance..... 8
7B. Winterizing the Pump..... 9

SECTION 8

Troubleshooting

- 8A. Troubleshooting..... 9

SECTION 9

Speciality Service

- 9A. Blocked Impeller..... 10
9B. Removing the Pump Housing..... 11
9C. Replacing the Pump Housing..... 12
9D. Mechanical Seal Replacement..... 13
9E. Motor Replacement..... 14

SECTION 10

Exploded View and Replacement Parts List

- 10A. Jandy™ HHP Pump Series..... 15
10B. Jandy™ MHP & MHPU Pump Series..... 17

SECTION 11

Pump Curves

- 11A. Jandy™ HHP & HHPU Pump Curves..... 18
11B. Jandy™ MHP & MHPU Pump Curves..... 19

SECTION 12

Pump Dimensions

- 12A. Jandy™ HHP & HHPU Pump
Dimensions..... 20
12B. Jandy™ MHP & MHPU Pump
Dimensions..... 21

Equipment Information Record

Date of Purchase _____ Purchased From _____

Pump Model _____ Horsepower _____

Serial Number _____

Installed by _____ Service Number _____

Notes: _____

SECTION 1. Safety Information

1A. Safety Instructions

READ AND FOLLOW THESE SAFETY INSTRUCTIONS! PLEASE SAVE THESE INSTRUCTIONS

Do not start pump dry! Running the pump dry for any length of time will cause severe damage and will void the warranty.

DANGER

1. Do not block pump suction, as this will cause severe or fatal injury if blocked with the body. Small children with access to the water must **ALWAYS** have close adult supervision.
2. Do not attempt to change the multiport valve position with the pump running.

WARNING

1. Do not install within an outdoor enclosure or beneath the skirt of a hot tub or portable spa.
2. To reduce the risk of injury, do not permit children to use this product unless they are closely supervised at all times.
3. The Jandy™ Pumps are powered by a high voltage electric motor and must be installed by a licensed or certified electrician or a qualified swimming pool service technician.
4. Due to the potential risk of fire, electric shock, or injuries to persons, Jandy™ Pumps must be installed in accordance with the National Electric Code, all local electrical and safety codes, and the Occupational Safety and Health Act (OSHA). Copies of the National Electrical Code may be ordered from the National Fire Protection Association, 470 Atlantic Ave., Boston, MA 02210, or contact your local government inspection agency.
5. Incorrectly installed equipment may fail, causing severe injury or property damage.
6. Equipment that is incorrectly pressure tested may fail, causing severe injury or property damage. Pressure testing should only be done by trained pool/spa professionals.
7. Chemical spills and fumes can weaken pool/spa equipment. Corrosion can cause filters and other equipment to fail, resulting in severe injury or property damage. Do not store pool chemicals near your equipment.

CAUTION

This pump is for use with permanently installed pools and may also be used with hot tubs and spas if so marked. Do not use with storable pools. A permanently installed pool is constructed in or on the ground or in a building such that it cannot be readily disassembled for storage. A storable pool is constructed so that it may be readily disassembled for storage and reassembled to its original integrity.

SECTION 2. General Information

2A. Introduction

This manual contains information for the proper installation and operation of Jandy™ Pumps. Procedures in this manual must be followed exactly. To obtain additional copies of this manual contact us at 707-776-8200, ext. 237. For address information see back cover.

2B. Description

Jandy™ Pumps are designed to meet the needs of today's more hydraulically demanding pool equipment. The pump housing, seal plate, diffuser, hair and lint pot, and impeller are all made from high quality thermoplastic materials. These materials were chosen for their strength and corrosion resistance.

The pump is driven by an electric motor directly attached to the pump impeller. As the electric motor turns it causes the impeller to turn which forces water to flow through the pump. The water flows into the hair/lint pot inlet and through the basket assembly. The basket assembly will pre-strain large particles. The flow then enters the center of the pump housing, goes through the impeller, into the diffuser, and out the pump discharge port.

Two Speed Pump Models- The hydraulic performance and priming of Jandy™ two speed pumps will be the same at high speed as the same model single speed pump. At low speed the pump will produce one half (½) the flow, and one quarter (¼) the pressure of high speed. The pressure required by the filter and pool plumbing at half flow will also be greatly reduced, due to much lower system friction. These lower friction losses result in increased energy savings. At one half flow (low speed) the electrical energy savings are 60% for equal amounts of circulated water.

Turn the motor to **low speed** for quiet operation and electrical cost savings. Since the pump should be operated at low speed for cost savings, minor adjustments may be required in the automatic chlorine dispenser, the skimmers and the heater due to the lower flow (see the equipment manufacturer's operation manuals).

Pool owners should use high speed for vacuuming the pool, quick filtering action, priming the heating system, and to keep up with heavy bathing loads. Spa owners will want to use high speed for good jet action.

SECTION 3. Preparation and Location

3A. Pump Preparation

1. Upon receipt of the Jandy™ Pump, check for carton damage. After opening the carton, check for concealed damage such as cracks, dents or a bent base. If damage is found contact the shipper or distributor where the pump was purchased.
2. Inspect for missing parts, unions, lid, or basket. See part lists on Pgs. 9-12.

3B. Pump Location

1. The pump should not be elevated more than a few feet above the water level of the pool, it is best to locate the pump within one (1) foot of the water level. A check valve is recommended on the suction line to the pump.
2. If the pump is located below water level, valves should be installed on both the suction and return lines to prevent back flow of pool water during any routine servicing that may be required.
3. The pump and other circulation equipment should be located a minimum of five (5) feet from the water. Choose a location that will minimize turns in the piping.
4. The pump must be placed on a solid foundation that will not vibrate. To further reduce the possibility of vibration noise the pump can be bolted down, or placed on a rubber mat.
5. The pump foundation must have adequate drainage to prevent the motor from getting wet. Protect the pump from the rain and sun.
6. Proper ventilation is required for the pump to operate normally. All motors generate heat that must be removed by providing proper ventilation.

7. Provide access for future service by leaving a clear area around the pump. Allow plenty of space above the pump to remove the lid and basket for cleaning.
8. If the equipment is under cover, provide adequate lighting.
4. The Jandy™ Pump must be connected to at least two separate suction points in the water. A drain and skimmer, two drains spaced apart, two skimmers, or a skimmer with an equalizer line installed. Check the local codes for proper installation.

SECTION 4. Piping Design & Installation

4A. Size of Suction Pipe

1. Recommended pipe size for the suction side of the pump is 2" for ¾ to 1½ HP. For 2 HP pumps recommended pipe size is 2½". For 3 HP pumps recommended pipe size is 3".

4B. Size of Discharge Pipe

1. Recommended pipe size for the discharge side of the pump is 2" for ¾ to 2 HP. For 3 HP pumps recommended pipe size is 2½".

Note: All pipe sizes are able to withstand the pressures the pump will deliver, but not the flow. If the pipe is too small for the pump, or it is elevated above water, the maximum gallons per minute (GPM) may not be delivered.

4C. Installation Tips

1. If the pump is located below water level, it may produce higher pressure compared to an above water installation. Isolation valves must be installed before and after the pump to prevent back flow of pool water during any routine servicing that may be required.
2. To help prevent difficulty in priming, install the suction pipe without high points which can trap air. For installations up to 100 feet from the water, the recommended pipe size must be used. For installations more than 100 feet from the water the recommended pipe must be increased to the next size.
3. The Jandy™ Pump comes equipped with 2" unions on both the suction and discharge ports. This feature will simplify installation, service, and eliminate the possibility of leaks at threaded adapters.

5. The piping must be well supported and not forced together where constant stress will be experienced.
6. Always use properly sized valves. Jandy™ Diverter Valves and Jandy™ Ball Valves typically have the best flow capabilities.
7. Use the fewest fittings possible. Every fitting added has the effect of moving the equipment farther away from the water. **Note:** If more than ten (10) suction fittings are needed, the pipe size must be increased.
8. Every new installation must be pressure tested according to local codes.

WARNING

Do not pressure test above 35 PSI. Pressure testing must be done by a trained pool professional. Circulation equipment that is not tested properly will fail, resulting in severe injury or property damage.

SECTION 5. Electrical Verification & Installation

5A. Check for Correct Voltage

1. The correct voltage, as specified on the pump nameplate is necessary for proper performance and long motor life. Incorrect voltage will decrease the pump's ability to perform and could cause overheating, reduce the motor life, and result in higher electric bills.
2. It is the responsibility of the electrical installer to provide nameplate operating voltage to the pump, by ensuring proper circuit sizes and wire sizes for this specific application.

⚠ Caution

Failure to provide nameplate voltage during operation within 10% will cause motor overheating and void the warranty.

5B. Bonding the Motor to the Pool Structure

1. The motor frame must be bonded to the pool/spa structure using a solid copper conductor, No. 8 AWG or larger.
2. Bond the motor using the external lug provided to all metal parts of the pool, spa, or hot tub and to all electrical equipment, metal piping, or conduit within five (5) feet of the inside walls of the pool, spa, or hot tub.

⚠ WARNING

Always disconnect the power source before working on a motor or its connected load.

⚠ Caution

The pump **must** be permanently connected to a dedicated electrical circuit. No other equipment, lights, appliances or outlets may be on the pump circuit.

⚠ WARNING

Install the control switch or time clock well away from the pool pump, filter, and other equipment for safety reasons. Should there be an equipment failure or loose fitting, access to the switch away from the failed equipment is important.

5C. Electrical Wiring

1. The pump motor must be securely and adequately grounded using the green screw provided. Ground before attempting to connect to an electrical power supply. **Do not ground to a gas supply line.**
2. Wire size must be adequate to minimize voltage drop during starting and operation of the pump. See Table 2 for suggested wire sizes.
3. Insulate all connections carefully to prevent grounding or short-circuits. Sharp edges on terminals require extra protection. Tape wire nuts to prevent loosening. For safety, and to prevent entry of contaminants, reinstall all conduit and terminal box covers. Do not force connections into the conduit box.
4. To connect the pump motor for the correct voltage, refer to the diagram on the nameplate.

Table 1- Wire Sizes (AWG #)

HP	Wire Sizes									
	Branch Fuse Amps		Up to 25 ft.		25 ft. - 50 ft.		50 ft. - 100 ft.		100 ft - 200 ft.	
	115V	230V	115V	230V	115V	230V	115V	230V	115V	230V
¾	#20	#15	#14	#14	#14	#14	#10	#14	#8	#12
1	#25	#15	#14	#14	#12	#14	#10	#14	#6	#12
1½	#30	#15	#12	#14	#10	#14	#8	#14	#6	#12
2	N/A	#25	N/A	#12	N/A	#14	N/A	#14	N/A	#10
3	N/A	#25	N/A	#12	N/A	#12	N/A	#12	N/A	#10

SECTION 6.

Start-up

6A. Pump Start-up

Caution

Never run the pump without water. Running the pump "dry" for any length of time can cause severe damage to both the pump and motor.

1. If this is a new pool installation, make sure all piping is clear of construction debris and has been properly pressure tested. The filter should be checked for proper installation, verifying all connections and clamps are secure according to the manufacturer's recommendations.
2. Release all pressure from the system and open the filter pressure release valve.
3. If the pump is located below the water level of the pool, opening the filter pressure release valve will prime the pump with water.
4. If the pump is located above the water level of the pool, remove the lid and fill the basket with water before starting the pump.
5. Prior to replacing the lid, check for debris around the lid o-ring seat. Debris around the lid o-ring seat will cause air to leak into the system, and make it difficult to prime the pump.
6. Clean the lid o-ring and place on the lid.
7. Hand tighten the lid to make an air tight seal. **Do not use any tools to tighten the lid, hand tighten only.**
8. Make sure all valves are open and the unions are tight.
9. Turn on the pump.
10. Once all the air has left the filter, close the pressure release valve.

11. The pump should prime. The time it takes to prime will depend on the elevation and length of pipe used on the suction supply pipe. See section 4 "Piping Design & Installation" for proper elevation and pipe size.
12. If the pump does not prime and all the instructions to this point have been followed, check for a suction leak.

SECTION 7.

Use and Maintenance

7A. General Maintenance

1. The pump will collect any large debris present in the water at the pump basket. As this debris accumulates it will begin to block the flow of water through the pump, and must be removed. The cleaner the basket is kept, the more effective and efficient the pump will perform. The pump lid is clear for easy inspection between cleaning.
2. To clean the basket, turn off the power to the pump. If the pump is located below the water level, close the isolation valves on the suction and discharge sides of the pump to prevent backflow of water. Turn the lid counter-clockwise until it comes off. You may use a tool for leverage to remove the lid, but **NEVER** to tighten the lid.

Caution

A misaligned basket will cause the lid to be improperly seated, allowing an air leak which could result in pump damage.

3. Lift the basket out of the pump.
4. Dispose of the debris and thoroughly clean the basket, making sure all the holes are open. Using a garden hose, spray the basket from the outside to help clear the holes. Use your hands to remove any remaining debris.
5. Replace the basket in the pump by aligning the opening with the suction pipe. If aligned properly, the basket will drop easily into place, **do not force.**

6. Prior to replacing the lid, check for debris around the lid o-ring seat, as this will cause air leaks into the system. Clean the lid o-ring and place on the lid.
7. Hand tighten the lid to make an air tight seal. **Do not use any tools to tighten the lid, hand tighten only.**
8. Verify that all valves have been returned to the proper position for pumping.
9. Open the pressure release valve on the filter, and make sure it is clean and ready for operation.
10. Turn on the power to the pump. Once all the air has been evacuated from the filter, close the pressure release valve.

7B. Winterizing the Pump

1. When freezing temperatures are expected, the Jandy™ Pump must be protected. Allowing the pump to freeze will cause severe damage and void the warranty.
2. Do not use antifreeze solutions in the pool, spa, or hot tub systems! Antifreeze is highly toxic and may damage the circulation system. The only exception to this is Propylene Glycol. For more information see your local pool/spa supply store or ask a qualified swimming pool service company.
3. Drain **all** water from the pump, system equipment, and piping.
4. The pump has two drain plugs that may be removed with a wrench. Do not use a screwdriver to remove or install the drain plugs.
5. Store the drain plugs in a safe location and reinstall them when the cold weather is over. Use a silicone sealant and wrench to tighten the drain plugs.
6. Keep the motor covered and dry. **Note:** Covering the pump with plastic will create condensation and this moisture will damage the pump. The best way to protect your pump is to have a qualified service technician or electrician properly disconnect the electrical wiring at the switch or junction box. Once the power is removed, the two unions can be

loosened and the pump stored indoors. For safety, and to prevent entry of contaminants, reinstall all conduit and terminal box covers.

7. When the system is reopened for operation, make sure all piping, valves, wiring, and equipment are in accordance with the manufacturer's recommendations. Pay close attention to the filter and electrical connections.
8. The pump must be primed prior to starting, in accordance with the "Start-up" instructions (Section 6) contained in this manual.

SECTION 8. Troubleshooting

8A. Troubleshooting

1. Water Pik Technologies, Inc. recommends that you call a qualified service technician to perform any repairs on the filter/pump system. For technical service call 707-776-8200, ext. 260.
2. The cleaning/circulating system is not working as well as in the past.
 - a. Are the skimmer baskets, pump basket and other screens clean?
 - b. Has the filter been cleaned recently?
 - c. Are all the valves adjusted correctly? Too much equipment on at one time will stop many cleaners from working (waterfalls, spa jets, surface returns, etc.).
 - d. Have you checked the cleaning system manual to make sure it is adjusted according to the manufacturer's recommendations.
3. Are there bubbles present in the pump basket?
 - a. Check the pool or spa water level to make sure it is at the proper level and that air is not being drawn into the suction piping. If the water is normal, continue with the next step.
 - b. Turn off the pump. Remove the lid. Check for debris around the lid o-ring seat, as this will cause air leaks into the system. Clean the lid o-ring and place on the lid. Hand tighten the lid to make an air tight seal. **Do NOT** use any tools to tighten the lid. Turn on the pump.

4. If there are still air leaks check the suction side piping union.
 - a. While the pump is running, try to tighten the union. If this does not stop the air leak, continue to the next step.
 - b. Turn off the pump.
 - c. Loosen both unions and slide the pump out of the way.
 - d. Remove, clean and place both union o-rings.
 - e. Reposition the pump next to the piping and secure the union nuts to the pump. With clean union o-rings, hand tightening of the unions should create a seal. If the unions still do not seal, **gently** tighten with a large tongue-and-groove pliers. **DO NOT** over tighten.
5. If there is no air in the system, but the pressure is still low.
 - a. It is possible that debris is caught in the pump impeller. The Impeller is what moves the water and has vanes that can become blocked with debris. See "Blocked Impeller" (Section 9A) under the "Specialty Service" section of this manual.
6. If there is nothing blocking the impeller and the pressure is still low. There are three other possible reasons for this;
 - a. The pump has been in an abrasive environment for a long period of time, and the impeller and diffuser are showing signs of wear. If the problem is normal wear on the Impeller and diffuser, have a qualified service technician replace them.
 - b. If this is a relatively new installation, it could be an electrical problem. This problem can be easily identified by a qualified service technician. Have the technician check for loose electrical connections and check the voltage at the pump motor while it is in operation. The voltage must be within 10% of the motor's nameplate rating. If it is not, then a qualified electrician and/or the power company needs to get involved to resolve the problem.
 - c. Pump seal is leaking air. Have a qualified service technician replace the seal.
7. The pump is leaking water between the motor and pump body.
 - a. This is caused by a damaged or failed mechanical seal. To solve this problem, the seal must be replaced. See "Mechanical Seal Replacement" under "Specialty Service" section of this manual.
8. The pump gets hot and shuts off periodically.
 - a. Make sure the motor has plenty of room to circulate air and keep cool. Have a qualified electrician check for loose connections and check the voltage at the pump motor while it is in operation. The voltage must be within 10% of the motor's nameplate rating. If it is not, then a qualified electrician and/or the power company needs to get involved to resolve the problem.

SECTION 9. Specialty Service

TWater Pik Technologies, inc. recommends that you call a qualified service technician to perform any repairs on the filter/pump system.

WARNING

While servicing the pump, switch off the circuit breakers at the power source. Severe personal injury or death may occur if the pump starts while your hand is inside the pump.

9A. Blocked Impeller

1. Turn off the pump. Switch off the circuit breaker to the pump motor.
2. Remove the lid and basket.
3. Look inside the pump for any debris. Remove any debris found inside.
4. Replace the basket and lid.
5. Switch on the circuit breaker to the pump motor.
6. Turn on the pump, and see if the problem is solved.
7. If the impeller is still blocked with debris and it is not possible to remove the debris this way, the pump will need to be disassembled to access the inlet and outlet of the impeller.

9B. Removing the Pump Body

1. Turn off the pump. Switch off the circuit breaker to the pump motor.
2. Loosen the suction and discharge unions. This will allow you to move the pump for easy opening. **Note:** Do not disconnect the wiring, but make sure the circuit breaker is off, so the pump will not turn on while open.
3. Using a wrench, loosen the bolts connecting the pump body to the mounting bracket (See Fig. 1).

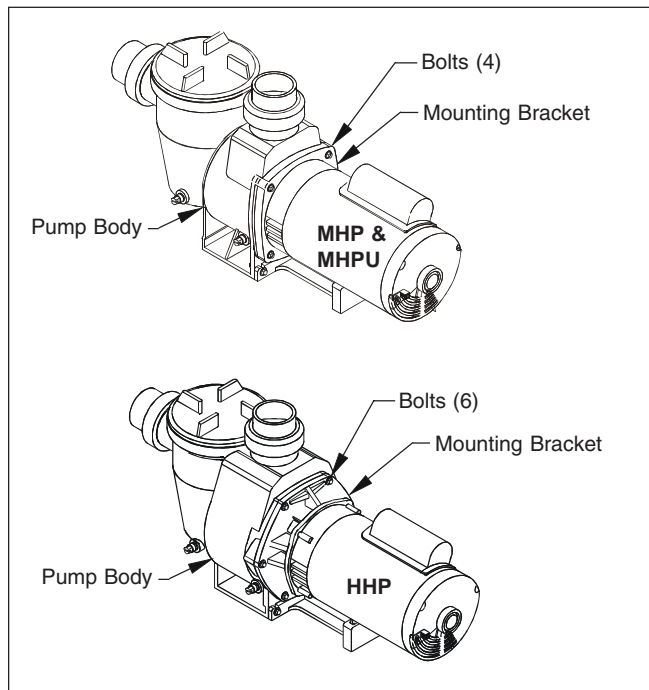

Figure 1. Removing the Pump Housing

4. Move the pump housing out of your way. Be careful not to lose or damage the o-rings. The impeller is connected to the motor side of the pump.
5. Remove the diffuser o-ring. It may be stuck on the pump body nozzle.
6. Using a No. 2 Phillips screwdriver, remove the four (4) screws holding the diffuser (the cover over the impeller) (See Fig.2).
7. Using a thin-blade screwdriver, gently pry the diffuser off the motor assembly by inserting it in between the diffuser and the mounting bracket. Gently lift while working your way around the diffuser. Do not force the diffuser off

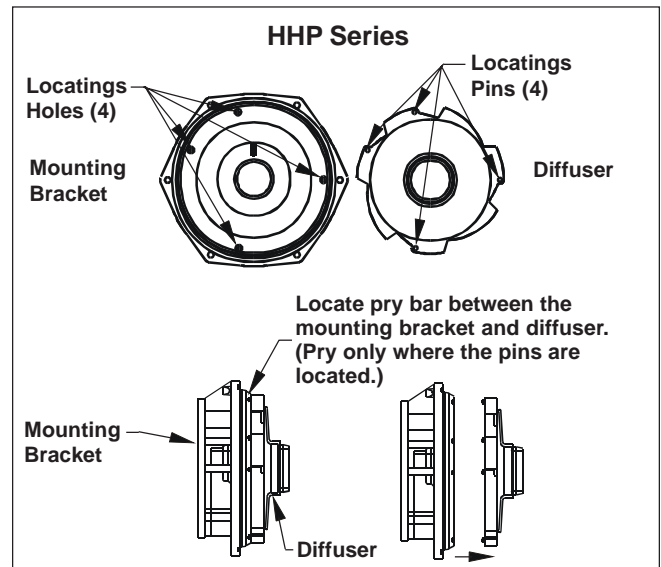

Figure 2. Removing the Diffuser HHP Series

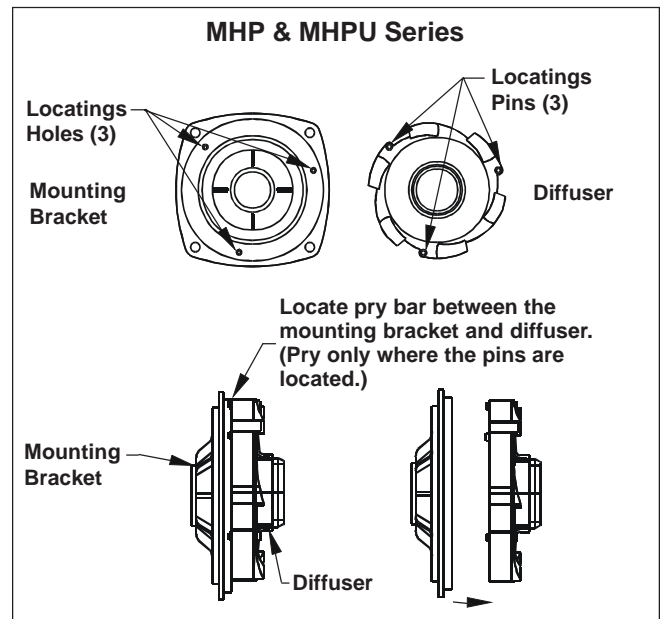

Figure 3. Removing the Diffuser MHP & MHPU Series

8. from one side (See Fig. 3). **Notice:** At this point you have access to the inlet and outlet of the impeller to remove any debris.
8. Remove the shaft cover on the back of the motor by prying with a flat head screwdriver. This will allow a wrench to be placed on the motor shaft and prevent it from rotating while the impeller is removed.
9. Turn the impeller counterclockwise, facing the opening, while holding the shaft from turning.

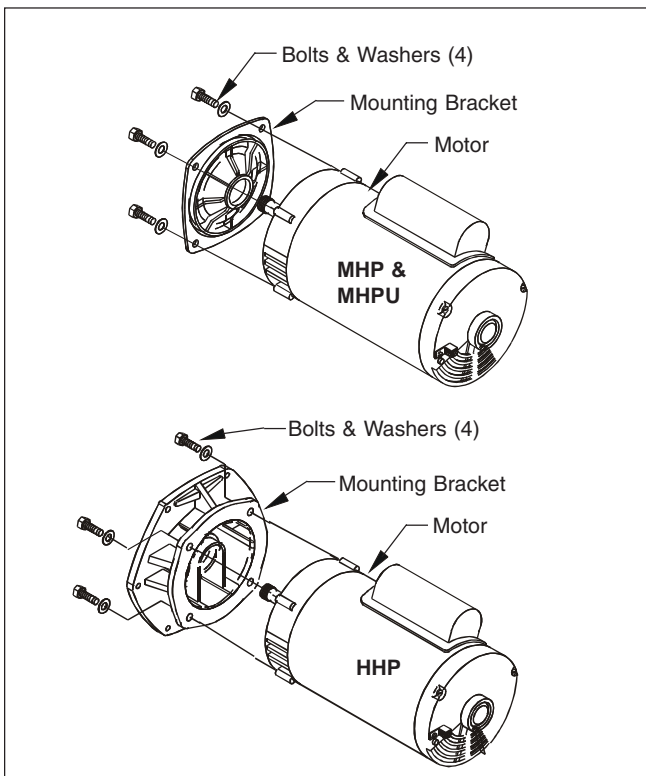

Figure 4. Mounting Bracket Assembly

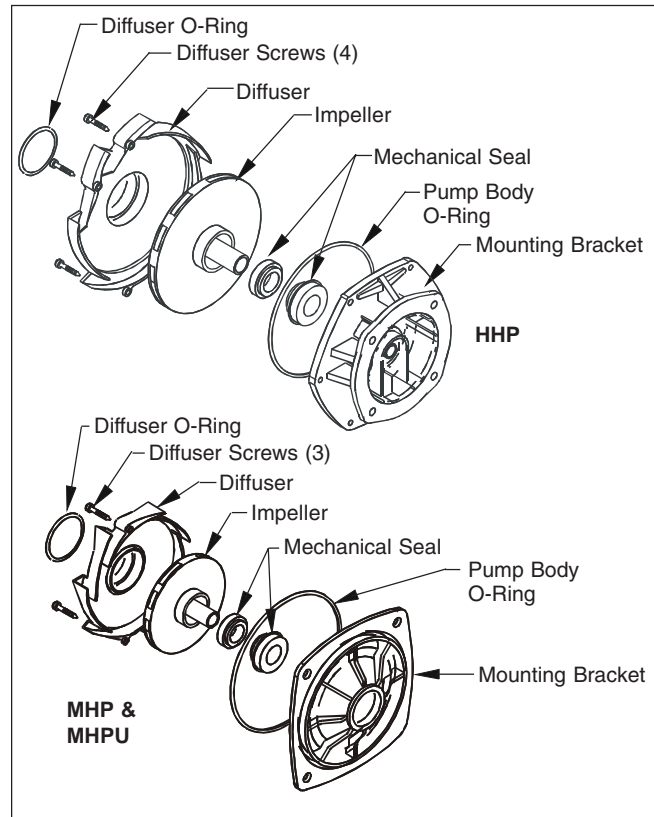

Figure 5. Mechanical Seal Replacement

- Remove the four (4) bolts holding the mounting bracket to the motor. Before removing the bracket, note the alignment of the mounting bracket to the motor (See Fig. 4).

9C. Replacing the Pump Body

- Replace the mounting bracket on the motor by first, aligning the bracket with the seal splash guard open to the ground, and the mounting bracket part number at the top. Install and tighten (max. 15 ft-lbs) the four (4) bolts (See Fig. 4).
- Thread the impeller back on the motor shaft while holding the shaft with a wrench. Hand tighten the impeller clockwise.
- Replace the motor shaft cover by tapping it back into place.
- Replace the diffuser on the mounting bracket assembly by snapping it into the screw holes. It will only fit one way (See Fig. 2).
- Replace the phillips head screws. Use the screws to tighten the diffuser flush against the mounting bracket. Tighten (max. 1 ft-lb) the screws by alternating between the top and bottom and left and right.
- There is an o-ring located between the diffuser and the pump body. Place the diffuser o-ring over the diffuser's suction side (See Fig. 5).
- Check for debris around the pump body o-ring seat, as this will cause leaks. Clean and place the o-ring on the mounting bracket assembly.
- Slide the pump body together with the motor assembly and press firmly, matching up the bolt holes.
- Replace the bolts by hand, making sure the washers are in place. Using a wrench, tighten the bolts. Use a star pattern to tighten the bolts. Do not over tighten (max. 6 ft-lbs).
- Verify that the union o-rings are still in place and free of debris.
- Reposition the pump next to the piping. Secure the union nuts to the pump. With clean union o-rings, hand tightening of the unions will create a seal.

12. If the pump is located above water level of the pool, remove the lid and fill the basket with water before starting the pump.
13. Prior to replacing the lid, check for debris around the lid o-ring seat, as this will cause air leaks into the system.
14. Hand tighten the lid to make an air tight seal. Do not use any tools to tighten the lid, hand tighten only.
15. Open the pressure release valve on the filter, and make sure it is clean and ready for operation.
16. Switch on the circuit breaker to the pump motor.
17. Turn on the pump.
18. Once all the air has left the filter, close the pressure release valve.

9D. Mechanical Seal Replacement

1. Follow steps 1-9 of "Removing the Pump Housing."
2. Remove the ceramic seal from the impeller first, by prying between the ceramic and the rubber gasket working in a circle, then remove the rubber seal. Do not pry between the rubber and the plastic impeller, as this will damage the impeller (See Fig. 6).

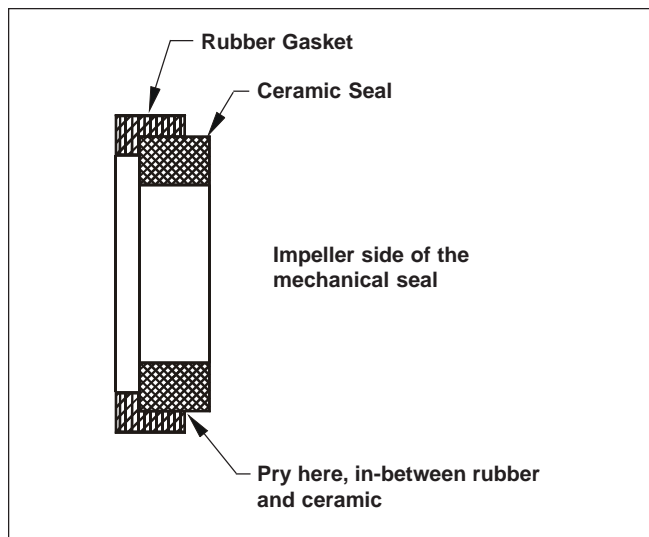

Figure 6. Mechanical Seal Replacement

3. Lubricate (water) the perimeter of the new seals rubber gasket.
4. Press the ceramic assembly onto the Impeller.
5. Use Windex or alcohol to remove any fingerprints from the ceramic seal.
6. Using a hammer, tap the old metal w/spring seal out of the mounting bracket from the back side.
7. Clean any silicone residue from the mounting bracket where the seal was removed.
8. Apply new silicone sealant to the perimeter of the new seal and press it into the mounting bracket by hand (See Fig. 7).
9. Follow steps 1 thru 18 of "Replacing the Pump Housing."

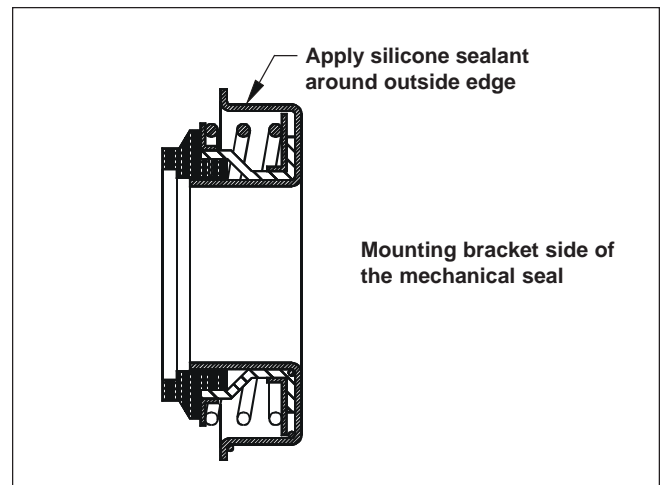

Figure 7. Mechanical Seal Replacement

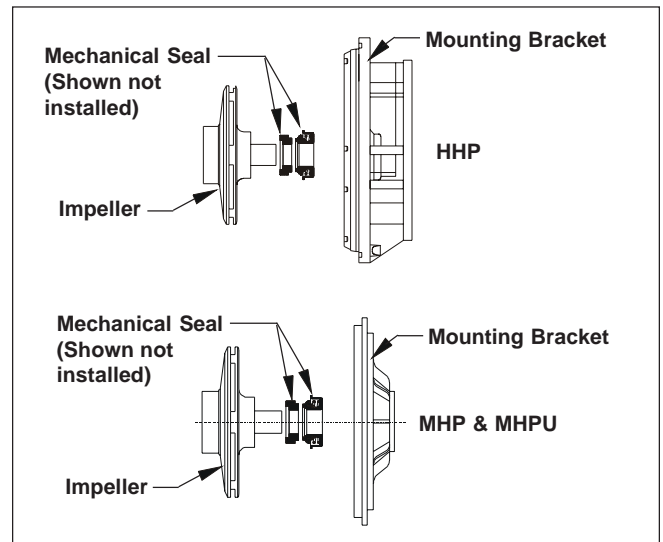

Figure 8. Mechanical Seal Replacement

9E. Motor Replacement

1. Have a qualified service technician or electrician properly disconnect the electrical wiring at the pump motor.
2. Follow steps 1-9 of "Removing the Pump Body."
3. Replace the motor with an identical make and model.
4. Follow steps 1 thru 18 of "Replacing the Pump Body."
5. Have a qualified service technician or electrician properly connect the electrical wiring at the pump motor.

Note: It is recommended that the seals be replaced at the same time the motor is replaced.

SECTION 10. Exploded Views & Replacement Kit Part Numbers

To order or purchase parts for Jandy Pumps, contact your nearest Water Pik Technologies Products dealer or distributor. If they cannot supply you with what you need, contact the Customer Service Manager at Water Pik Technologies, Inc.

10A. Jandy™ HHP & HHPU Pump Series

Key No.	Description	Size (HP)	ORDER PART NO:
1	Motor, single-speed HHP Series	.75	R0337701
1	Motor, single-speed HHP Series	1.0	R0337702
1	Motor, single-speed HHP Series	1.5	R0337703
1	Motor, single-speed HHP Series	2.0	R0337704
1	Motor, single-speed HHP Series	3.0	R0337705
1	Motor, 2-speed HHP Series	1.5	R0337803
1	Motor, 2-speed HHP Series	2.0	R0337804
2	Mounting Bracket	All	R0337900
3	Impeller, HHP Series	.75	R0338001
3	Impeller, HHP Series	1.0	R0338002
3	Impeller, HHP Series	1.5	R0338003
3	Impeller, HHP Series	2.0	R0338004
3	Impeller, HHP Series	3.0	R0338005
4	Diffuser	.75-2.0	R0338101
4	Diffuser	3.0	R0338105
5	Mechanical Seal	All	R0338200
6	Body, Pump Face Assy. HHP Series	.75-2.0	R0338301
6	Body, Pump Face Assy. HHP Series	3.0	R0338305
7	Mounting Foot Assy.	All	R0338400
8	Pot Lid	All	R0338500
9	Pot Basket	All	R0338600
12	O-ring, -264, Body,	All	R0338700
13	O-ring, -330, Diffuser	.75-2.0	R0338801
13	O-ring, -330, Diffuser	3.0	R0338805
14	O-ring, -359, Pot Lid	All	R0338900
15	Hardware Set (4), Diffuser Mntg. ¹	All	R0339000
23	Drain Plugs (2)	All	R0339100
24	Hardware Set (2), Foot Mntg. ¹	All	R0339200
25	Hardware Set (6), Bracket Mntg. ¹	All	R0339300
26	Hardware Set (4) Motor Mntg. ¹	All	R0339400
27	Coupling Nut Set	All	R0339500
28	O-ring, -332 (2), Coupling Set	All	R0339600
	O-ring Set, Complete (6)	All	R0340900
	Hardware Set, Complete	All	R0341000

NOTES:

1. All hardware sets contain all pieces necessary for assembly.
2. All replacement kits include all hardware and o-rings needed to replace the ordered part.

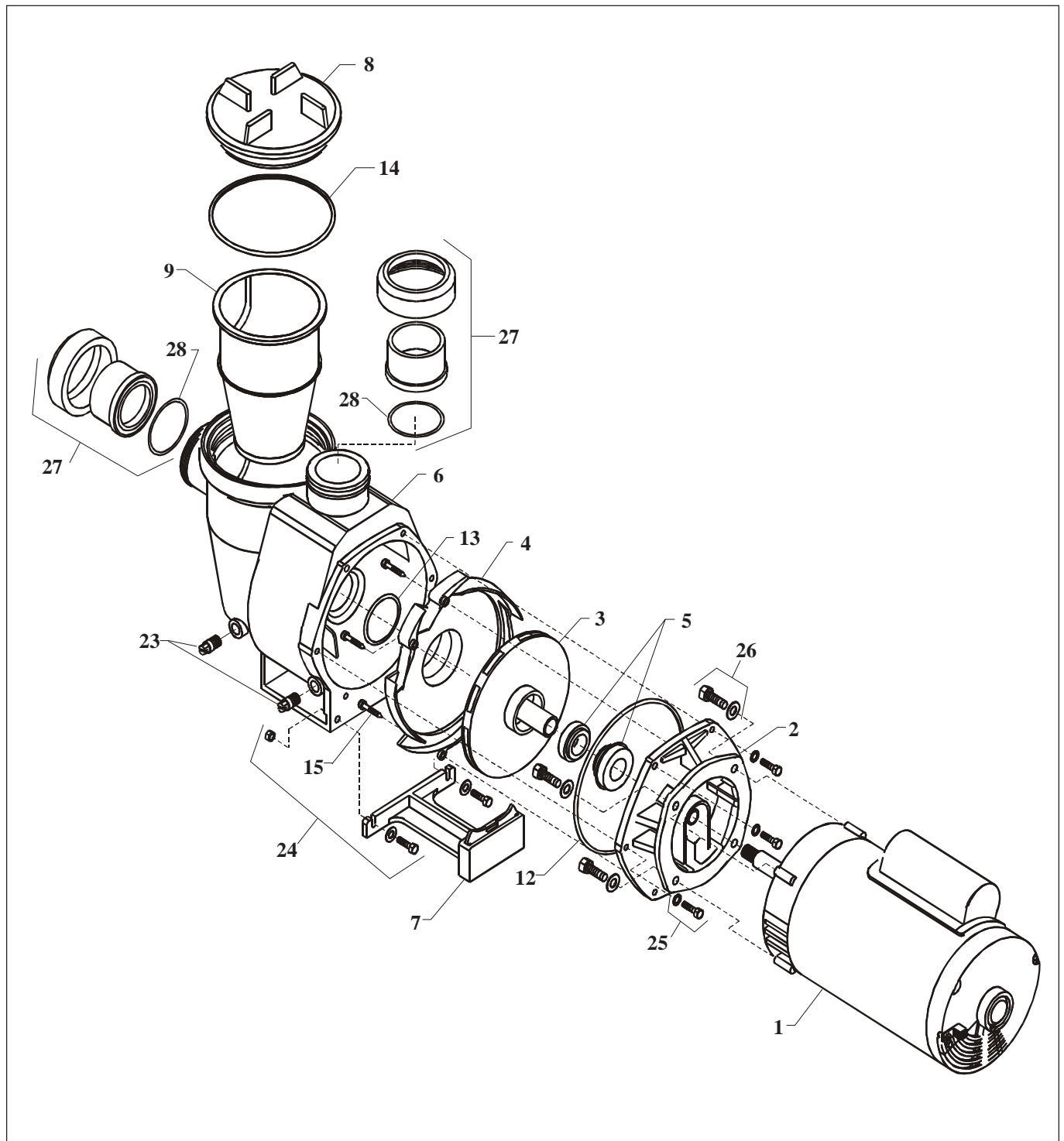

Figure 9. HHP Exploded View

To order or purchase parts for Jandy™ Pumps, contact your nearest Water Pik Technologies Products dealer or distributor. If they cannot supply you with what you need, contact the Customer Service Manager at Water Pik Technologies, Inc.

10B. Jandy™ MHP & MHPU Pump Series

Key No.	Description	Size (HP)	ORDER PART NO:
50	Motor, Full Rated, MHP Series	.75	R0339701
50	Motor, Full Rated, MHP Series	1.0	R0339702
50	Motor, Full Rated, MHP Series	1.5	R0339703
50	Motor, Full Rated, MHP Series	2.0	R0339704
50	Motor, Up-Rated, MHPU Series	.75	R0339801
50	Motor, Up-Rated, MHPU Series	1.0	R0339802
50	Motor, Up-Rated, MHPU Series	1.5	R0339803
50	Motor, Up-Rated, MHPU Series	2.0	R0339804
50	Motor, Up-Rated, MHPU Series	2.5	R0339805
51	Mounting Bracket	All	R0339900
52	Impeller, MHP Series	.75	R0340002
52	Impeller, MHP Series	1.0	R0340003
52	Impeller, MHP Series	1.5	R0340004
52	Impeller, MHP Series	2.0	R0340005
52	Impeller, MHPU Series	.75	R0340001
52	Impeller, MHPU Series	1.0	R0340002
52	Impeller, MHPU Series	1.5	R0340003
52	Impeller, MHPU Series	2.0	R0340004
52	Impeller, MHPU Series	2.5	R0340005
53	Diffuser	All	R0340100
5	Mechanical Seal	All	R0338200
54	Body, Pump Face Assy.	All	R0340200
55	Mounting Foot Assy.	All	R0340300
8	Pot Lid	All	R0338500
9	Pot Basket	All	R0338600
56	O-ring, -259, Body	All	R0340400
13	O-ring, -330, Diffuser	All	R0338800
14	O-ring, -359, Pot Lid	All	R0338900
57	Hardware Set (3), Mntg. Diffuser ¹	All	R0340500
23	Drain Plugs (2)	All	R0339100
58	Hardware Set (2), Mntg. Foot ¹	All	R0340600
59	Hardware Set (4) Mntg. Motor ¹	All	R0340700
27	Coupling Nut Set	All	R0339500
28	O-ring, -332 (2), Coupling Set	All	R0339600
	O-ring Set, Complete (6)	All	R0341100
	Hardware Set, Complete	All	R0341200

NOTES:

1. All hardware sets contain all pieces necessary for assembly.
2. All replacement kits include all hardware and o-rings needed to replace the ordered part.

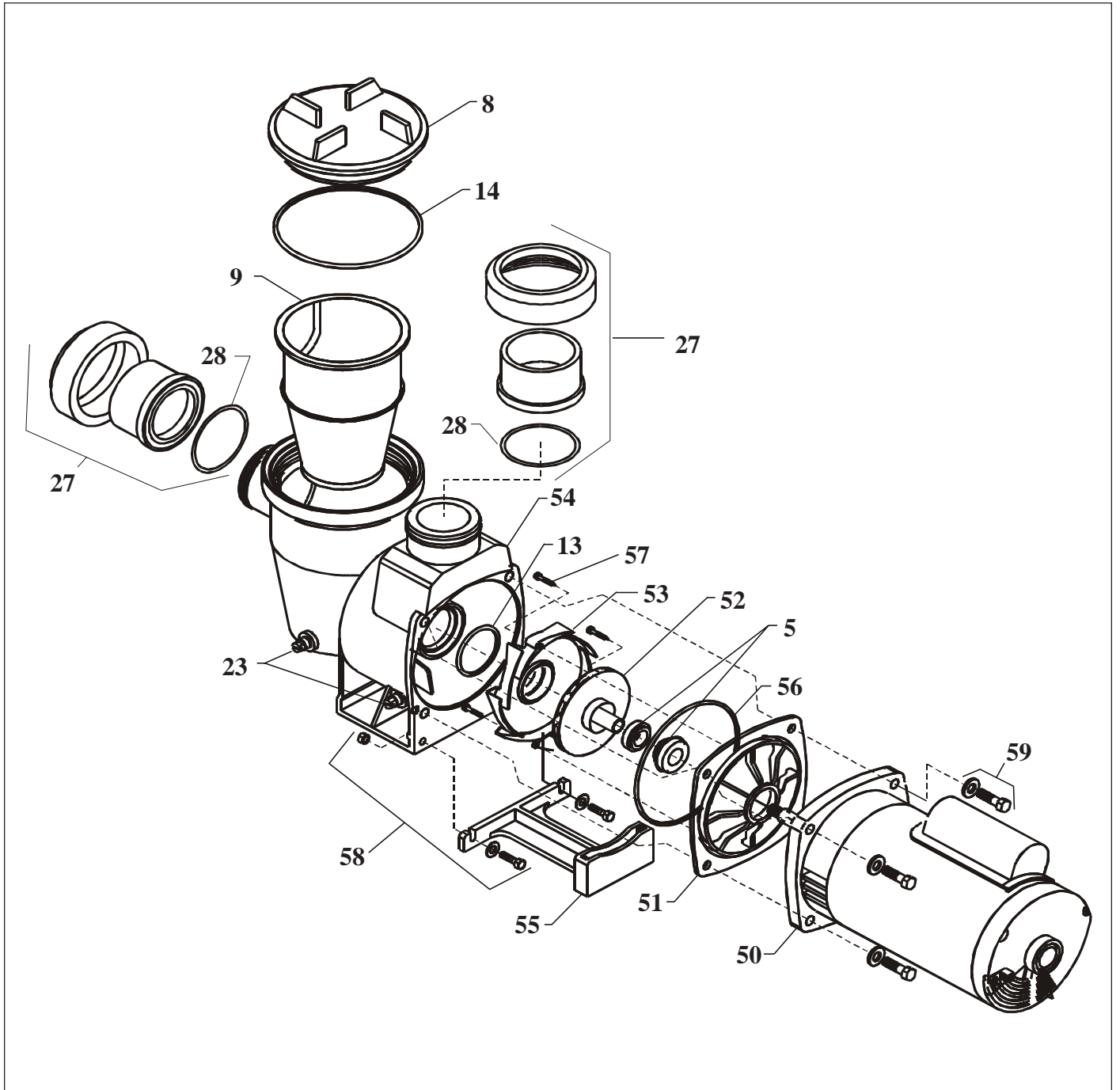

Figure 10. MHP & MHPU Exploded View

SECTION 11. Pump Curves

11A. Jandy™ HHP & HHPU Pump Curves

- 3.0HHP
- - - - - 2.0HHP/2.5HHPU
- · - · - · 1.5HHP/2.0HHPU
- · · · · 1.0HHP/1.5HHPU
- · - · - · 0.75HHP/1.0HHPU

P
S
I Feet
of
Head

Jandy High Head Pumps
Full Rated (HHP) & Up Rated (HHPU)

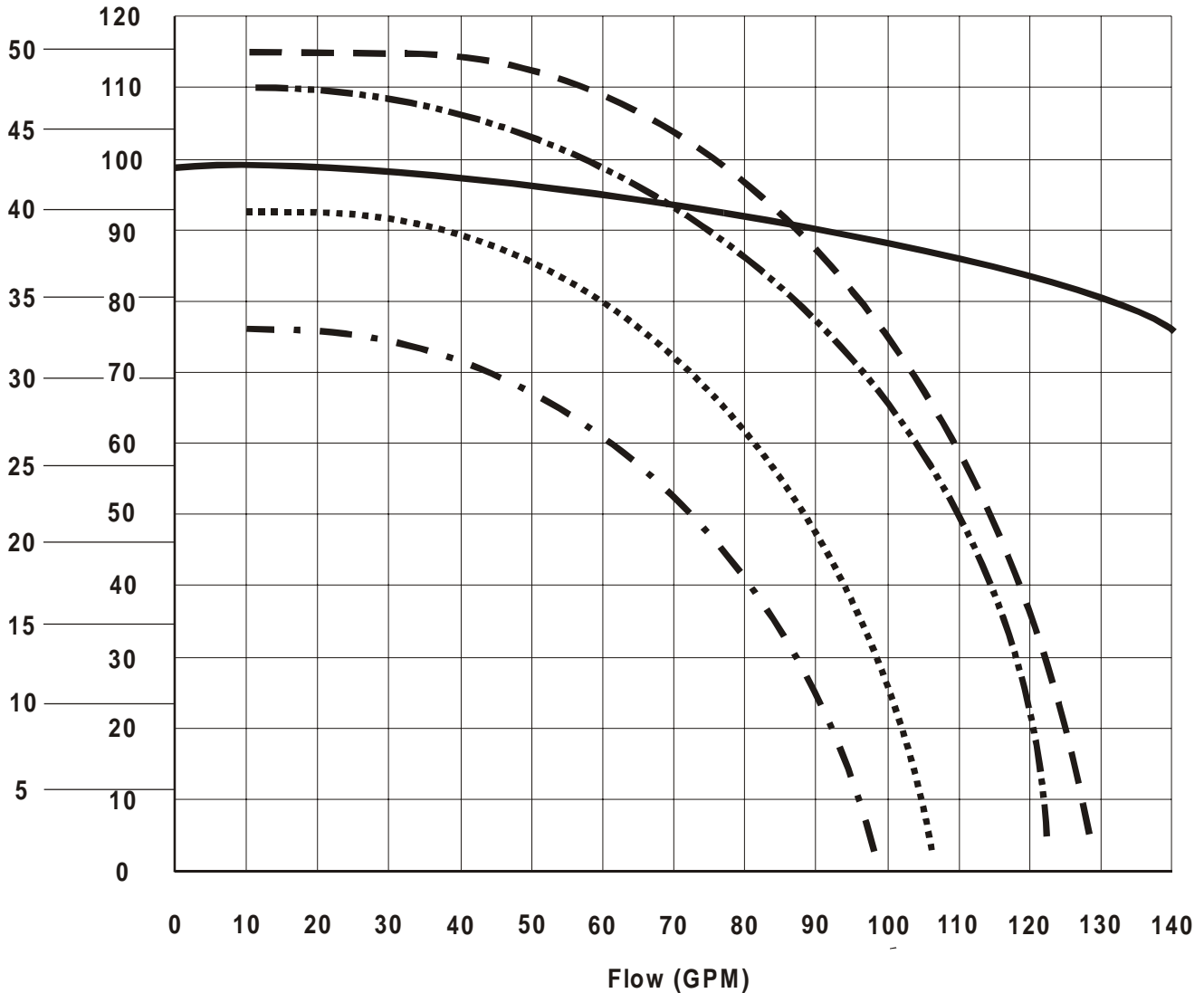

11B. Jandy™ MHP & MHPU Pump Curves

- 2.0MHP / 2.5MHPU
- . - . - . 1.5MHP / 2.0MHPU
- - - - - 1.0MHP / 1.5MHPU
-75MHP / 1.0MHPU
-75MHPU

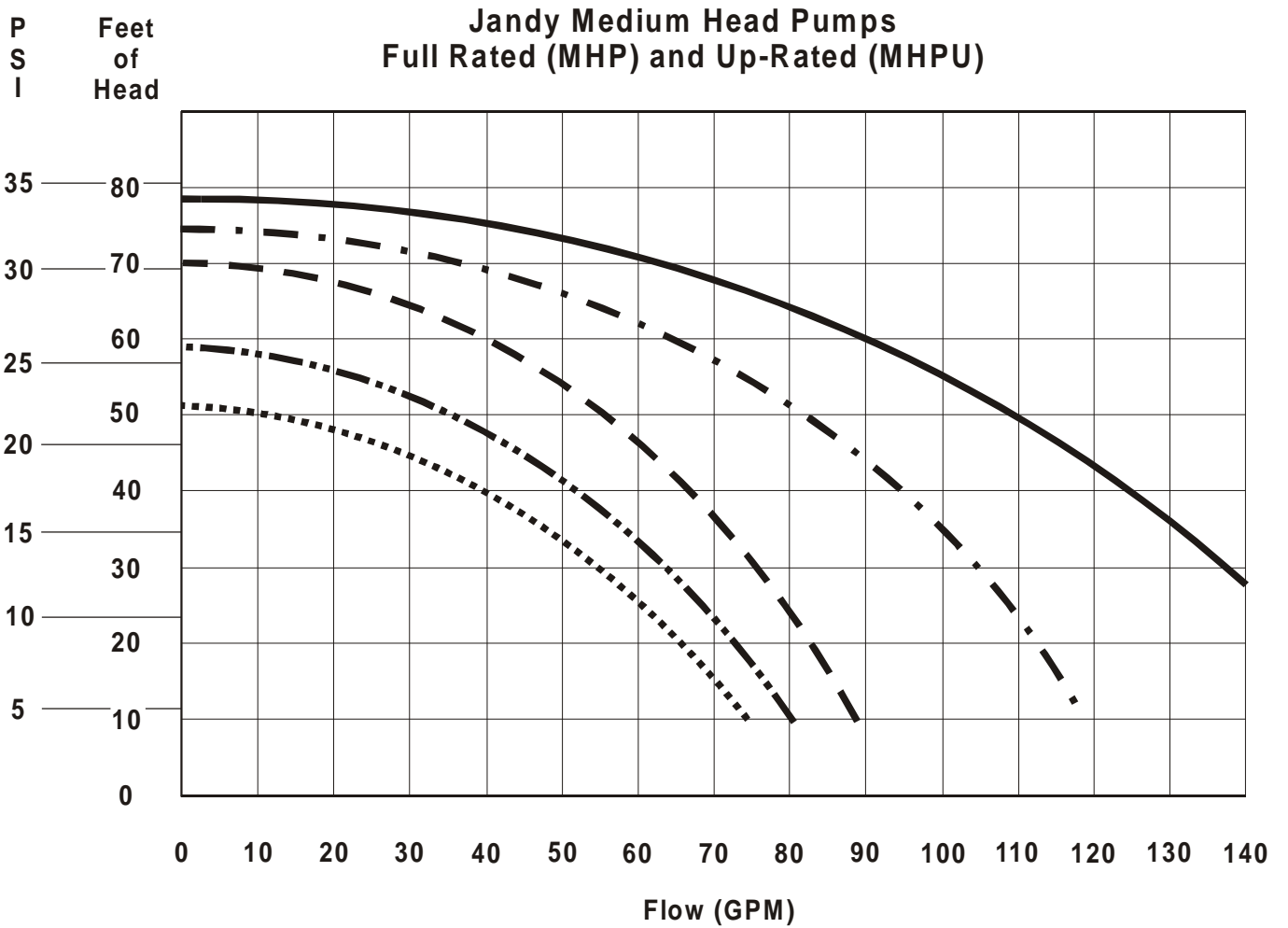

SECTION 12. Pump Dimensions

12A. Jandy™ HHP & HPU Pump Dimensions

MODEL NO.	HP	VOLTAGE	PIPE SIZE	CARTON WEIGHT	DIMENSIONS	
					A	B
HHP.75	.75	115/230	2"	38lbs.	23 ¹ / ₈ "	13 ³ / ₈ "
HHP1.0	1.0	115/230	2"	41lbs.	23 ¹ / ₂ "	13 ¹ / ₄ "
HHP1.5	1.5	115/230	2"	47lbs.	24 ¹ / ₂ "	14 ¹ / ₄ "
HHP2.0	2.0	230	2"	51lbs.	25"	14 ³ / ₄ "
HHP3.0	3.0	230	2"	59lbs.	27 ¹ / ₈ "	16 ⁷ / ₈ "
HHPU1.0	1.0	115/230	2"	38lbs.	23 ³ / ₈ "	13 ¹ / ₈ "
HHPU1.5	1.5	115/230	2"	41lbs.	23 ¹ / ₂ "	13 ¹ / ₄ "
HHPU2.0	2.0	230	2"	47lbs.	24 ¹ / ₂ "	14 ¹ / ₄ "
HHPU2.5	2.5	230	2"	51lbs.	25"	14 ³ / ₄ "

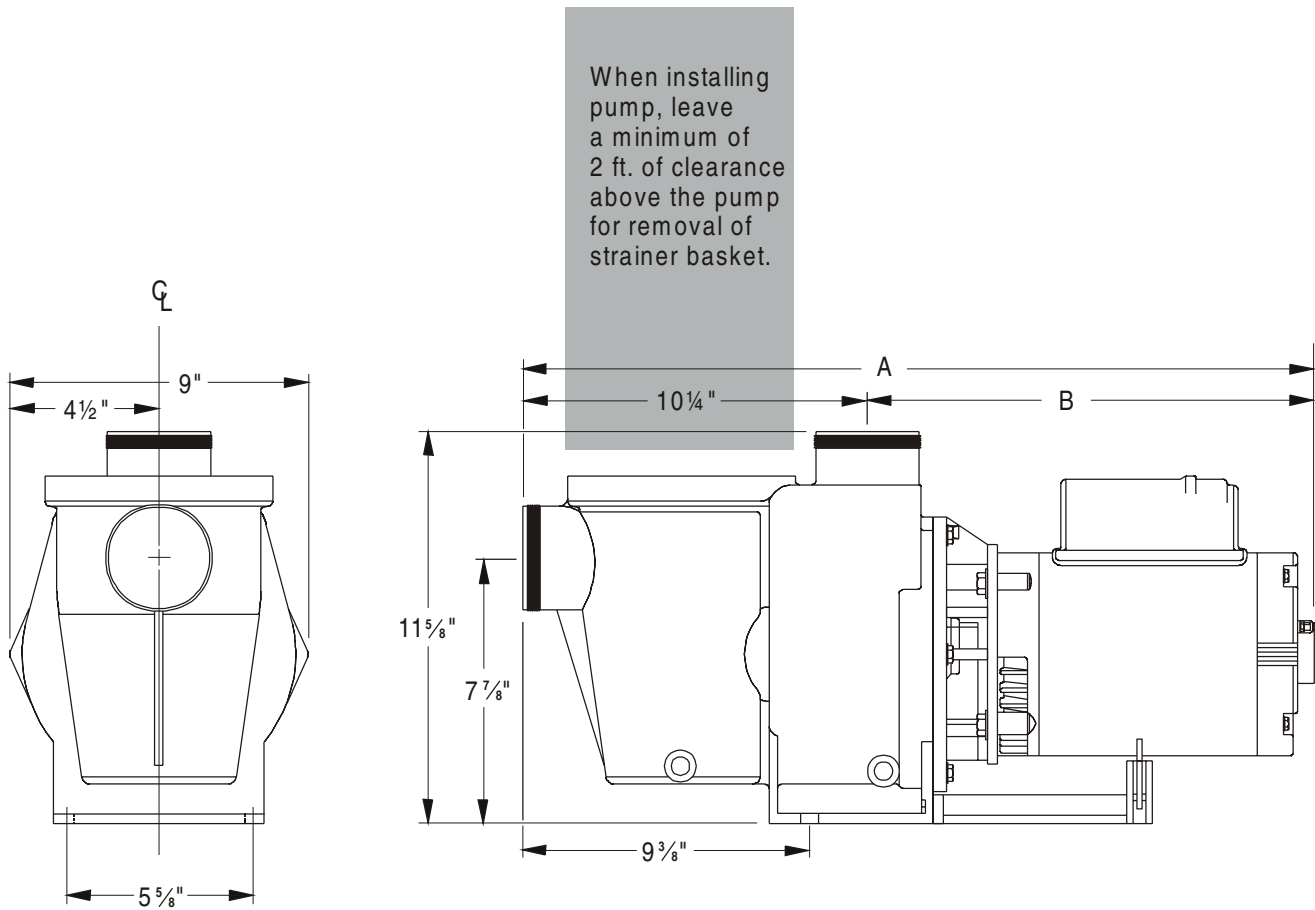

12B. Jandy™ MHP & MHPU Pump Dimensions

MODEL NO.	HP	VOLTAGE	PIPE SIZE	CARTON WEIGHT	DIMENSIONS	
					A	B
MHP.75	.75	115/230	2"	38lbs.	23¾"	13¼"
MHP1.0	1.0	115/230	2"	41lbs.	23¾"	13¼"
MHP1.5	1.5	115/230	2"	47lbs.	23¾"	13¼"
MHP2.0	2.0	230	2"	51lbs.	24¼"	13¾"
MHPU.75	.75	115/230	2"	36lbs.	23¾"	13¼"
MHPU1.0	1.0	115/230	2"	38lbs.	23¾"	13¼"
MHPU1.5	1.5	115/230	2"	41lbs.	23¾"	13¼"
MHPU2.0	2.0	115/230	2"	47lbs.	23¾"	13¼"
MHPU2.5	2.5	230	2"	51lbs.	24¼"	13¾"

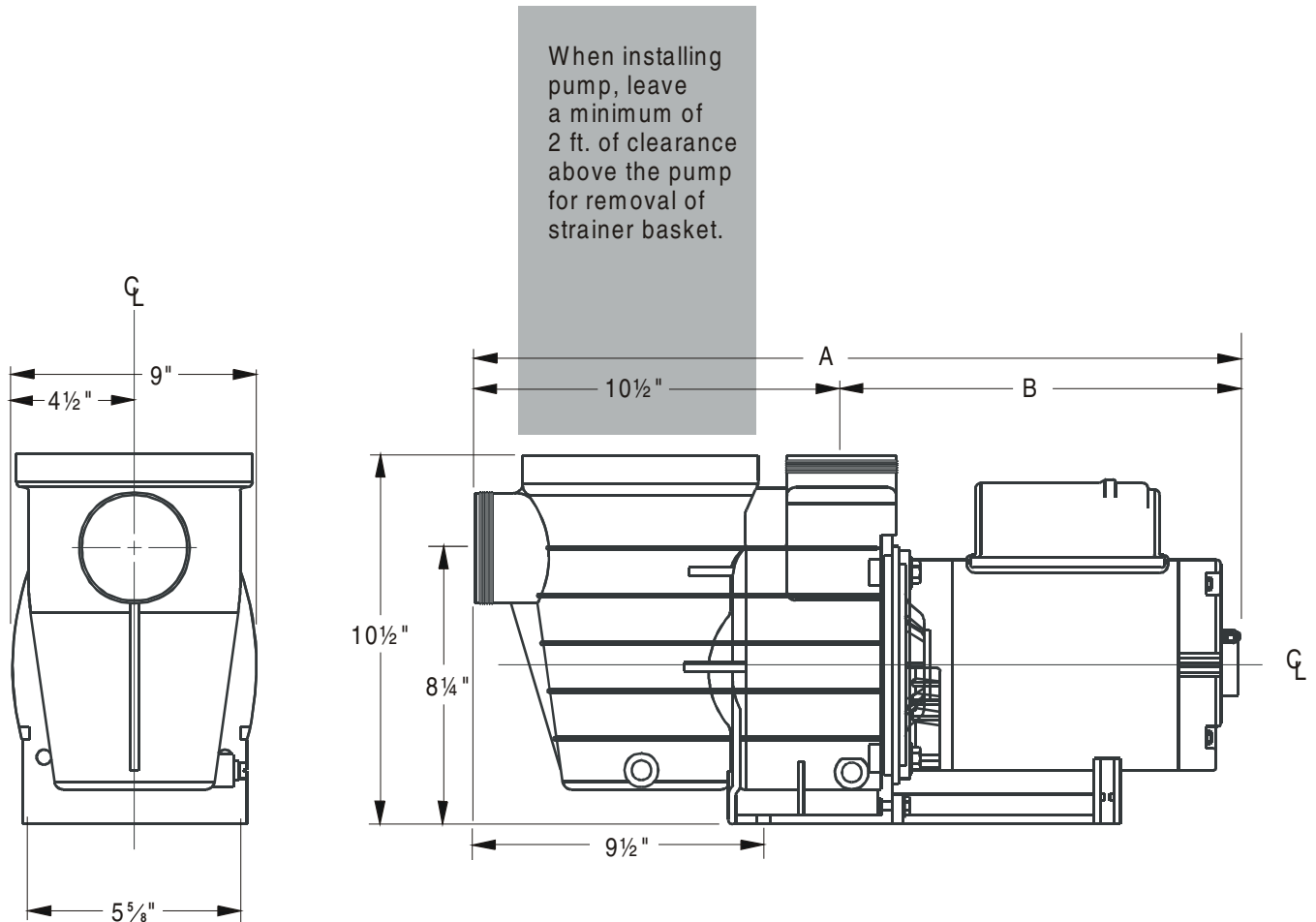

Limited Warranty

Your Jandy Brand Pump is backed by this double warranty protection.

1. A parts warranty on the "wet end" components of the pump against defects in material and workmanship for a full one (1) year from date of purchase.
2. A parts warranty on the electric motor, through the motor manufacturer, against defects in material and workmanship for a full two (2) years from date of purchase.

The above warranty applies to the original purchaser only, and is enforceable only if the installation and operating instructions applicable to the model purchased are expressly and completely followed. This warranty excludes the mechanical pump seal and "o" rings and any failures caused by starting or operating the pump without sufficient water, freeze damage, or insufficient electrical supply. The liability of Water Pik Technologies, Inc. shall not exceed the repair or replacement of defective parts and shall not include transportation to or from the factory, any labor costs, and consequential or

incidental damages. For warranty consideration of inoperative Jandy brand pumps, contact your local dealer or pool service company, or for a service center near you, call Water Pik Technologies, Inc. at (707) 776-8200.

This warranty gives you specific legal rights. You may also have other rights which vary from state to state, and by province. Some states and provinces do not allow the exclusion or limitation of incidental or consequential damages, so the above limitation or exclusion may not apply to you.



6000 Condor Dr., Moorpark, CA 93021* USA (805) 529-2000
480 S. Service Road West, Oakville, Ontario, Canada L6K 2G4 (905) 844-823



UL 1081
CSA C22.2 NO 108-M89



Jandy
Pumps

waterpik
Technologies, Inc.

6000 Condor Drive, Moorpark, CA, USA 93021 • 707.776.8200 FAX 707.763.7785
480 S. Service Road West, Oakville, Ontario, Canada L6K 2H4 • 905.844.8233 FAX 905.844.2635

Litho in U.S.A. © Water Pik Technologies, Inc. 2001

For Technical Support call 707-776-8200, ext. 260