

Installation and Operation Manual

Stealth Series Pumps

(Models JHP & JHPU)

WARNING

FOR YOUR SAFETY: This product must be installed and serviced by a professional service technician, qualified in pool/spa installation. The procedures in this manual must be followed exactly. Improper installation and/or operation can create dangerous electrical hazards which can cause high voltages to run through the electrical system, possibly causing death, serious injury or property damage. Improper installation and/or operation will void the warranty.



ATTENTION INSTALLER:

This manual contains important information about the installation, operation and safe use of this product. This information should be given to the owner/operator of this equipment.

TABLE OF CONTENTS

SECTION 1. Safety Information

- 1.1 Safety Instructions..... 4

SECTION 2. General Information

- 2.1 Introduction.....5
2.2 Description..... 5

SECTION 3. Preparation and Location

- 3.1 Pump Preparation..... 5
3.2 Pump Location.....5

SECTION 4. Piping Design and Installation

- 4.1 Size of Suction Pipe..... 5
4.2 Size of Discharge Pipe.....5
4.3 Installation Tips..... 6

SECTION 5. Electrical Verification and Installation

- 5.1 Checking for Correct Voltage..... 6
5.2 Bonding Motor to Pool Structure..... 6
5.3 Electrical Wiring.....7

SECTION 6. Start-up

- 6.1 Pump Start-up.....7

SECTION 7. Use and Maintenance

- 7.1 General Maintenance..... 8
7.2 Winterizing the Pump..... 8

SECTION 8. Troubleshooting

- 8.1 Troubleshooting.....9

SECTION 9. Speciality Service

- 9.1 Blocked Impeller..... 10
9.2 Removing the Impeller..... 10
9.3 Replacing the Impeller..... 11
9.4 Mechanical Seal Replacement..... 12
9.5 Motor Replacement..... 13

SECTION 10. Exploded View and Replacement Parts List

- 10.1 Jandy® JHP & JHPU Pump Series..... 14

SECTION 11. Pump Curves

- 11.1 Jandy® JHP & JHPU Pump Curves..... 16

SECTION 12. Pump Dimensions

- 12.1 Jandy® JHP & JHPU Pump Dimensions..... 17

Equipment Information Record

Date of Purchase _____ Purchased From _____

Pump Model _____ Horsepower _____

Serial Number _____ Service Number _____

Installed by _____

Notes: _____

SECTION 1. Safety Information

1.1 IMPORTANT SAFETY INSTRUCTIONS

When installing and using this electrical equipment, basic safety precautions should always be followed, including the following:

1. READ AND FOLLOW ALL INSTRUCTIONS

DANGER

2. Do not block pump suction, as this will cause severe or fatal injury if blocked with the body.

WARNING

3. To reduce the risk of injury, do not permit children to use this product unless they are closely supervised **at all times**.
4. Do not attempt to change the multiport valve position with the pump running.
5. The Jandy® Pumps are powered by a high voltage electric motor and must be installed by a licensed or certified electrician or a qualified swimming pool service technician.
6. Due to the potential risk of fire, electric shock, or injuries to persons, Jandy® Pumps must be installed in accordance with the National Electric Code, all local electrical and safety codes, and the Occupational Safety and Health Act (OSHA). Copies of the National Electrical Code may be ordered from the National Fire Protection Association, 470 Atlantic Ave., Boston, MA 02210, or contact your local government inspection agency.
7. Incorrectly installed equipment may fail, causing severe injury or property damage.
8. Equipment that is incorrectly pressure tested may fail, causing severe injury or property damage. Pressure testing should only be done by trained pool/spa professionals.
9. Chemical spills and fumes can weaken pool/spa equipment. Corrosion can cause filters and other equipment to fail, resulting in severe injury or property damage. Do not store pool chemicals near your equipment.

CAUTION

10. Do not start pump dry! Running the pump dry for any length of time will cause severe damage and will void the warranty.
11. This pump is for use with permanently installed pools and may also be used with hot tubs and spas if so marked. Do not use with storable pools. A permanently installed pool is constructed in or on the ground or in a building such that it cannot be readily disassembled for storage. A storable pool is constructed so that it may be readily disassembled for storage and reassembled to its original integrity.
12. Do not install within an outdoor enclosure or beneath the skirt of a hot tub or portable spa.

13. SAVE THESE INSTRUCTIONS

SECTION 2. General Information

2.1 Introduction

This manual contains information for the proper installation, operation and maintenance of Jandy® Stealth Pumps. Procedures in this manual must be followed exactly. To obtain additional copies of this manual contact us at 707-776-8200, ext. 237. For address information see back cover.

2.2 Description

Jandy® Stealth Pumps are designed to meet the needs of today's more hydraulically demanding pool equipment. The pump housing, seal plate, diffuser, hair and lint pot (pump basket), and impeller are all made from high quality thermoplastic materials. These materials were chosen for their strength and corrosion resistance.

The pump is driven by an electric motor directly attached to the pump impeller. As the electric motor turns it causes the impeller to turn which forces water to flow through the pump. The water flows into the hair/lint pot inlet and through the basket assembly. The basket assembly will pre-strain large particles. The flow then enters the center of the pump housing, goes through the impeller, into the diffuser, and out the pump discharge port.

SECTION 3. Preparation and Location

3.1 Pump Preparation

1. Upon receipt of the pump, check for carton damage. After opening the carton, check for concealed damage such as cracks, dents or a bent base. If damage is found contact the shipper or distributor where the pump was purchased.
2. Inspect for missing parts, unions, lid, or basket. See the part lists on page 14.

3.2 Pump Location

1. The pump should not be elevated more than a few feet above the water level of the pool, it is best to locate the pump within one (1) foot of the water level. A check valve is recommended on the suction line to the pump.

2. If the pump is located below water level, valves should be installed on both the suction and return lines to prevent back flow of pool water during any routine servicing that may be required.
3. The pump and other circulation equipment must be located more than five (5) feet from the water. Choose a location that will minimize turns in the piping.
4. The pump must be placed on a solid foundation that will not vibrate. To further reduce the possibility of vibration noise the pump can be bolted down, or placed on a rubber mat.
5. The pump foundation must have adequate drainage to prevent the motor from getting wet. Protect the pump from the rain and sun.
6. Proper ventilation is required for the pump to operate normally. All motors generate heat that must be removed by providing proper ventilation.
7. Provide access for future service by leaving a clear area around the pump. Allow plenty of space above the pump to remove the lid and basket for cleaning.
8. If the equipment is under cover, provide adequate lighting.

SECTION 4. Piping Design & Installation

4.1 Size of Suction Pipe

1. Recommended pipe size for the suction side of the pump is 2" for ¾ to 1½ HP. For 2 HP pumps recommended pipe size is 2½". For 3 HP pumps recommended pipe size is 3".

4.2 Size of Discharge Pipe

1. Recommended pipe size for the discharge side of the pump is 2" for ¾ to 2 HP. For 3 HP pumps recommended pipe size is 2½".

Note: All pipe sizes are able to withstand the pressures the pump will deliver, but not the flow. If the pipe is too small for the pump, or it is elevated above water, the maximum gallons per minute (GPM) may not be delivered.

4.3 Installation Tips

1. If the pump is located below water level, it may produce higher pressure compared to an above water installation. Isolation valves must be installed before and after the pump to prevent back flow of pool water during any routine servicing that may be required.
2. To help prevent difficulty in priming, install the suction pipe without high points which can trap air. For installations up to 100 feet from the water, the recommended pipe size must be used. For installations more than 100 feet from the water the recommended pipe must be increased to the next size.
3. Stealth Pumps come equipped with unions on both the suction and discharge ports. This feature will simplify installation, service, and eliminate the possibility of leaks at threaded adapters.
4. The Stealth Pump must be connected to at least two (2) separate suction points in the water. A drain and skimmer, two drains spaced apart, two skimmers, or a skimmer with an equalizer line installed. Check the local codes for proper installation.
5. The piping must be well supported and not forced together where constant stress will be experienced.
6. Always use properly sized valves. Jandy Diverter Valves and Jandy Ball Valves typically have the best flow capabilities.
7. Use the fewest fittings possible. Every fitting added has the effect of moving the equipment farther away from the water. **Note:** If more than ten (10) suction fittings are needed, the pipe size must be increased.
8. Every new installation must be pressure tested according to local codes.

WARNING

Do not pressure test above 35 PSI. Pressure testing must be done by a trained pool professional. Circulation equipment that is not tested properly will fail, resulting in severe injury or property damage.

SECTION 5. Electrical Verification & Installation

5.1 Check for Correct Voltage

1. The correct voltage, as specified on the pump data plate, is necessary for proper performance and long motor life. Incorrect voltage will decrease the pump's ability to perform and could cause overheating, reduce the motor life, and result in higher electric bills.
2. It is the responsibility of the electrical installer to provide data plate operating voltage to the pump, by ensuring proper circuit sizes and wire sizes for this specific application.

Caution

Failure to provide data plate voltage (within 10%) during operation will cause motor overheating and void the warranty.

5.2 Bonding the Motor to the Pool Structure

1. The motor frame must be bonded to the pool/spa structure using a solid copper conductor, No. 8 AWG or larger.
2. Bond the motor using the external lug provided to all metal parts of the pool, spa, or hot tub and to all electrical equipment, metal piping, or conduit within five (5) feet of the inside walls of the pool, spa, or hot tub.

WARNING

Always disconnect the power source before working on a motor or its connected load.

Caution

The pump **must** be permanently connected to a dedicated electrical circuit. No other equipment, lights, appliances or outlets may be on the pump circuit.

WARNING

Install the control switch or time clock well away from the pool pump, filter, and other equipment for safety reasons. Should there be an equipment failure or loose fitting, access to the switch away from the failed equipment is important.

5.3 Electrical Wiring

1. The pump motor must be securely and adequately grounded using the green screw provided. Ground before attempting to connect to an electrical power supply. **Do not ground to a gas supply line.**
2. Wire size must be adequate to minimize voltage drop during starting and operation of the pump. See Table 1 for suggested wire sizes.
3. Insulate all connections carefully to prevent grounding or short-circuits. Sharp edges on terminals require extra protection. Tape wire nuts to prevent loosening. For safety, and to prevent entry of contaminants, reinstall all conduit and terminal box covers. Do not force connections into the conduit box.
4. To connect the pump motor for the correct voltage, refer to the diagram on the data plate.

3. If the pump is located below the water level of the pool, opening the filter pressure release valve will prime the pump with water.
4. If the pump is located above the water level of the pool, remove the lid and fill the basket with water before starting the pump.
5. Prior to replacing the lid, check for debris around the lid o-ring seat. Debris around the lid o-ring seat will cause air to leak into the system, and make it difficult to prime the pump.
6. Hand tighten the lid to make an air tight seal. **Do not use any tools to tighten the lid, hand tighten only.** Make sure all valves are open and the unions are tight.
7. Turn on the pump.
8. Once all the air has left the filter, close the pressure release valve.
9. The pump should prime. The time it takes to prime will depend on the elevation and length of pipe used on the suction supply pipe. See section 4 "Piping Design & Installation" for proper elevation and pipe size.
10. If the pump does not prime and all the instructions to this point have been followed, check for a suction leak and then repeat steps 2-9 of this section.

SECTION 6. Start-up

⚠ Caution

Never run the pump without water. Running the pump "dry" for any length of time can cause severe damage to both the pump and motor.

6.1 Pump Start-up

1. If this is a new pool installation, make sure all piping is clear of construction debris and has been properly pressure tested. The filter should be checked for proper installation, verifying all connections and clamps are secure according to the manufacturer's recommendations.
2. Release all pressure from the system and open the filter pressure release valve.

HP	Wire Sizes									
	Branch Fuse Amps		Up to 25 ft.		25 ft. - 50 ft.		50 ft. - 100 ft.		100 ft - 200 ft.	
	115V	230V	115V	230V	115V	230V	115V	230V	115V	230V
¾	20A	15A	#14	#14	#14	#14	#10	#14	#8	#12
1	25A	15A	#14	#14	#12	#14	#10	#14	#6	#12
1½	30A	15A	#12	#14	#10	#14	#8	#14	#6	#12
2	N/A	25A	N/A	#12	N/A	#14	N/A	#14	N/A	#10
3	N/A	25A	N/A	#12	N/A	#12	N/A	#12	N/A	#10

Table 1- Wire Sizes (AWG #)

SECTION 7. Use and Maintenance

7.1 General Maintenance

1. The pump will collect any large debris present in the water at the pump basket. As debris accumulates it will begin to block the flow of water through the pump, and must be removed. The cleaner the basket is kept, the more effective and efficient the pump will perform. The pump lid is clear for easy inspection between cleaning.
2. To clean the basket, turn off the power to the pump. If the pump is located below the water level, close the isolation valves on the suction and discharge sides of the pump to prevent backflow of water. Turn the lid counter-clockwise until it comes off. You may use a tool for leverage to remove the lid, but **NEVER** to tighten the lid.

Caution

A misaligned basket will cause the lid to be improperly seated, allowing an air leak which could result in pump damage.

3. Lift the basket out of the pump.
4. Dispose of the debris and thoroughly clean the basket, making sure all the holes are open. Using a garden hose, spray the basket from the outside to help clear the holes. Use your hands to remove any remaining debris.
5. Replace the basket in the pump by aligning the opening with the suction pipe. If aligned properly, the basket will drop easily into place, **do not force.**
6. Prior to replacing the lid, check for debris around the lid o-ring seat, as this will cause air leaks into the system. Clean the lid o-ring and place on the lid.
7. Hand tighten the lid to make an air tight seal. **Do not use any tools to tighten the lid, hand tighten only.**
8. Verify that all valves have been returned to the proper position for normal operation.

9. Open the pressure release valve on the filter, and make sure it is clean and ready for operation.
10. Turn on the power to the pump. Once all the air has been evacuated from the filter, close the pressure release valve.

7.2 Winterizing the Pump

1. When freezing temperatures are expected, the pump must be protected. Allowing the pump to freeze will cause severe damage and void the warranty.
2. Do not use antifreeze solutions in the pool, spa, or hot tub systems! Antifreeze is highly toxic and may damage the circulation system. The only exception to this is Propylene Glycol. For more information see your local pool/spa supply store or contact a qualified swimming pool service company.
3. Drain **all** water from the pump, system equipment, and piping.
4. The pump has two drain plugs that may be removed by hand.
5. Store the drain plugs in a safe location and reinstall them when the cold weather is over.
6. Keep the motor covered and dry. **Note:** Covering the pump with plastic will create condensation and this moisture will damage the pump. The best way to protect your pump is to have a qualified service technician or electrician properly disconnect the electrical wiring at the switch or junction box. Once the power is removed, the two unions can be loosened and the pump stored indoors. For safety, and to prevent entry of contaminants, reinstall all conduit and terminal box covers.
7. When the system is reopened for operation, make sure all piping, valves, wiring, and equipment are in accordance with the manufacturer's recommendations. Pay close attention to the filter and electrical connections.
8. The pump must be primed prior to starting, in accordance with the "Start-up" instructions (Section 6.1) contained in this manual.

SECTION 8. Troubleshooting

8.1 Troubleshooting

1. Jandy strongly recommends that you call a qualified service technician to perform any repairs on the filter/pump system. To locate a qualified technician, check your local yellow pages or visit www.jandy.com and click on "Product Support."
2. The cleaning/circulating system is not working as well as in the past.
 - a. Are the skimmer baskets, pump basket and other screens clean?
 - b. Has the filter been cleaned recently?
 - c. Are all the valves adjusted correctly? Too much equipment on at one time will stop many cleaners from working (waterfalls, spa jets, surface returns, etc.).
 - d. Have you checked the cleaning system manual to make sure it is adjusted according to the manufacturer's recommendations.
3. Are there bubbles present in the pump basket?
 - a. Check the pool or spa water level to make sure it is at the proper level and that air is not being drawn into the suction piping. If the water is normal, continue with the next step.
 - b. Turn off the pump. Remove the lid. Check for debris around the lid o-ring seat, as this will cause air leaks into the system. Clean the lid o-ring and place on the lid. Hand tighten the lid to make an air tight seal. Do **NOT** use any tools to tighten the lid. Turn on the pump.
4. If there are still air leaks, check the suction side piping union.
 - a. While the pump is running, try to tighten the union. If this does not stop the air leak, continue to the next step.
 - b. Turn off the pump.
 - c. Loosen both unions and slide the pump out of the way.
 - d. Remove, clean and replace both union o-rings.
 - e. Reposition the pump next to the piping and secure the union nuts to the pump. With clean union o-rings, hand tightening of the unions should create a seal. If the unions still do not seal, **gently** tighten with a large pair of tongue-and-groove pliers. **DO NOT** over tighten.
5. If there is no air in the system, but the pressure is still low.
 - a. It is possible that debris is caught in the pump impeller. The impeller is what moves the water and has vanes that can become blocked with debris. See "Blocked Impeller" (Section 9.1) under the "Specialty Service" section of this manual.
6. If there is nothing blocking the impeller and the pressure is still low, there are three other possible reasons for this:
 - a. The pump has been in an abrasive environment for a long period of time, and the impeller and diffuser are showing signs of wear. If the problem is normal wear on the impeller and diffuser, have a qualified service technician replace them.
 - b. If this is a relatively new installation, it could be an electrical problem. This problem can be easily identified by a qualified service technician. Have the technician check for loose electrical connections and check the voltage at the pump motor while it is in operation. The voltage must be within 10% of the motor's data plate rating. If it is not, then a qualified electrician and/or the power company needs to get involved to resolve the problem.
 - c. Pump seal is leaking air. Have a qualified service technician replace the seal.
7. The pump is leaking water between the motor and pump body.
 - a. This is caused by a damaged or failed mechanical seal. To solve this problem, the seal must be replaced. See "Mechanical Seal Replacement" (Section 9.4) under "Speciality Service" section of this manual.
8. The pump gets hot and shuts off periodically.
 - a. Make sure the motor has plenty of room to circulate air and keep cool. Have a qualified electrician check for loose connections and check the voltage at the pump motor while it is in operation. The voltage must be within 10% of the motor's data plate rating. If it is not, then a qualified electrician and/or the power company needs to get involved to resolve the problem.

SECTION 9.

Specialty Service

Jandy strongly recommends that you call a qualified service technician to perform any repairs on the filter/pump system.

9.1 Blocked Impeller

1. Turn off the pump. Switch off the circuit breaker to the pump motor.

⚠ WARNING

While servicing the pump, switch off the circuit breakers at the power source. Severe personal injury or death may occur if the pump starts while your hand is inside the pump.

2. Remove the lid and basket.
3. Look inside the pump for any debris. Remove any debris found inside.
4. Replace the basket and lid.
5. Switch on the circuit breaker to the pump motor.
6. Turn on the pump, and see if the problem is solved.
7. If the impeller is still blocked with debris and it is not possible to remove the debris this way, the pump will need to be disassembled to access the inlet and outlet of the impeller.

9.2 Removing the Impeller

1. Turn off the pump. Switch off the circuit breaker to the pump motor. If you are not replacing the motor, do not disconnect the electrical wiring.
Note: If you are replacing the motor, Jandy strongly recommends that a qualified service technician or electrician properly disconnect the electrical wiring at the pump motor.
2. Turn off any valves to prevent pool water from reaching the pump. Drain the water from the pump by loosening the unions or removing the drain plugs.
3. Using a wrench, loosen the bolts connecting the pump body to the mounting bracket (See Fig. 1).

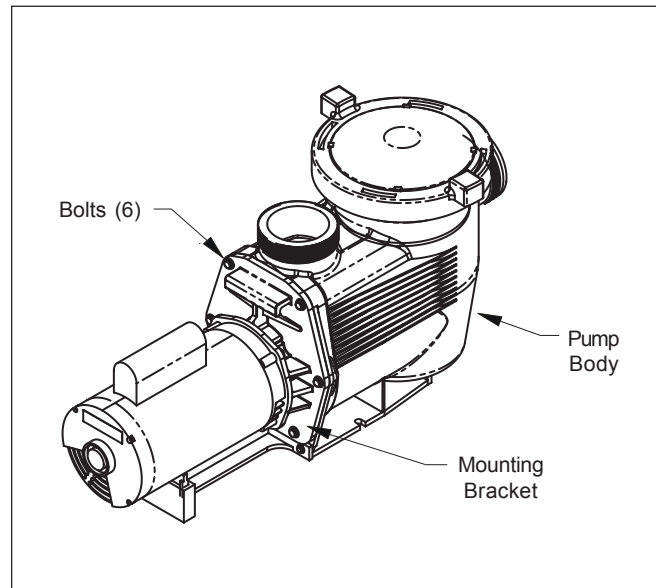

Figure 1. Removing the Pump Housing

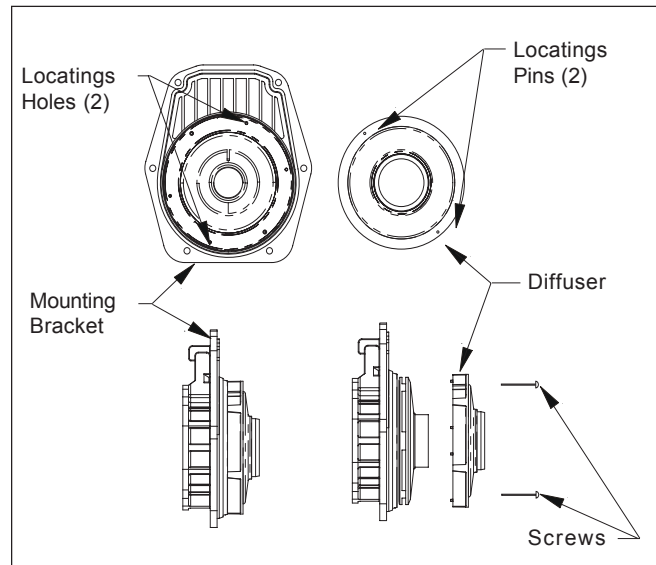

Figure 2. Removing the Diffuser

4. Pull the motor and mounting bracket out of the pump body. The impeller is connected to the motor shaft.
5. Using a No. 1 Phillips screwdriver, remove the two (2) screws holding the diffuser (the cover over the impeller) and remove the diffuser (See Fig. 2). Remove the diffuser o-ring. It may be stuck in the pump body cone (See Fig. 3).
Note: At this point you have access to the inlet and outlet of the impeller to remove any debris.

6. Remove the motor shaft cover on the backend of the motor by prying it off with a flat head screwdriver. This will allow a wrench to be placed on the motor shaft and prevent it from rotating while the impeller is removed.
7. Turn the impeller counterclockwise, while holding the motor shaft still.
11. Hand tighten the lid to make an air tight seal. Do not use any tools to tighten the lid, hand tighten only.
12. Open the pressure release valve on the filter, and make sure it is clean and ready for operation.
13. Switch on the circuit breaker to the pump motor.

9.3 Replacing the Impeller

1. Thread the impeller back on the motor shaft while holding the shaft with a wrench. Hand tighten the impeller clockwise.
2. Replace the motor shaft cover by tapping it back into place.
3. Replace the diffuser on the mounting bracket assembly by snapping it into the screw holes.
4. Replace the Phillips head screws. Use the screws to tighten the diffuser flush against the mounting bracket. Tighten to a maximum of 1 ft-lb.
5. There is an o-ring located between the diffuser and the pump body cone. Place the diffuser o-ring over the diffuser's suction side (See Fig. 3).
6. Check for debris around the pump body o-ring seat, as this will cause leaks. Clean and place the o-ring on the mounting bracket assembly.
7. Slide the motor assembly into the pump body and press firmly, matching up the bolt holes.
8. Replace the bolts, making sure the washers are in place. Use a star pattern to tighten the bolts. Do not over tighten (max. 6 ft-lbs).
9. If the pump is located above water level of the pool, remove the lid and fill the basket with water before starting the pump.
10. Prior to replacing the lid, check for debris around the lid o-ring seat, as this will cause air leaks into the system.
14. Turn on the pump and check the system for normal operation.
15. Once all the air has left the filter, close the pressure release valve.

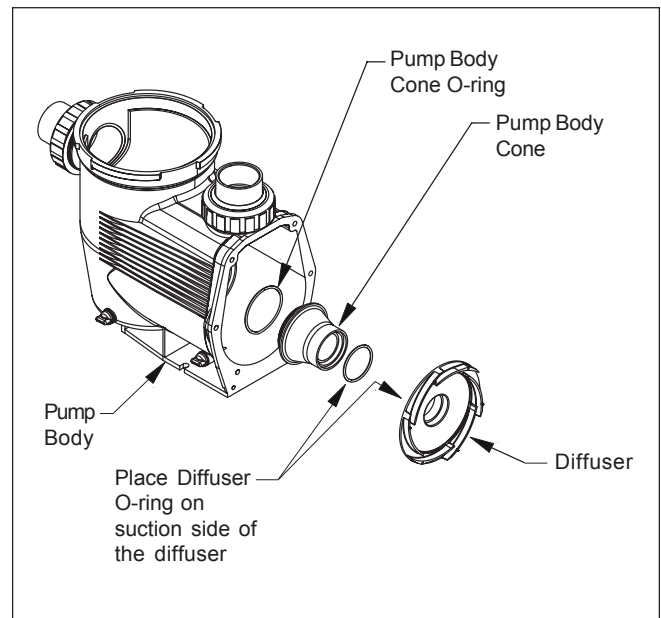

Figure 3. Diffuser O-ring

9.4 Mechanical Seal Replacement

1. Follow steps 1-7 of section 9.2, "Removing the Impeller."
2. Remove the ceramic seal from the impeller first, by prying between the ceramic and the rubber gasket working in a circle, then remove the rubber seal. Do not pry between the rubber and the plastic impeller, as this will damage the impeller (See Fig. 5).
3. Lubricate (water) the perimeter of the new seals rubber gasket.
4. Press the new ceramic seal and rubber gasket assembly onto the impeller.
5. Use Windex or alcohol to remove any fingerprints from the ceramic seal.
6. Using a hammer, tap the old metal w/spring seal out of the mounting bracket from the back side.
7. Clean any silicone residue from the mounting bracket where the seal was removed.
8. Apply new silicone sealant to the perimeter of the new seal and press it into the mounting bracket by hand (See Fig. 6).
9. Follow steps 1 thru 15 of section 9.3, "Replacing the Impeller."

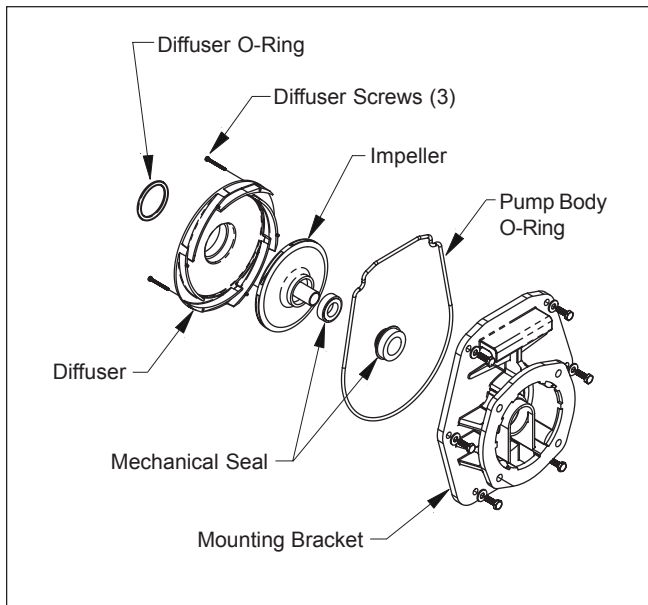

Figure 4. Mechanical Seal Replacement

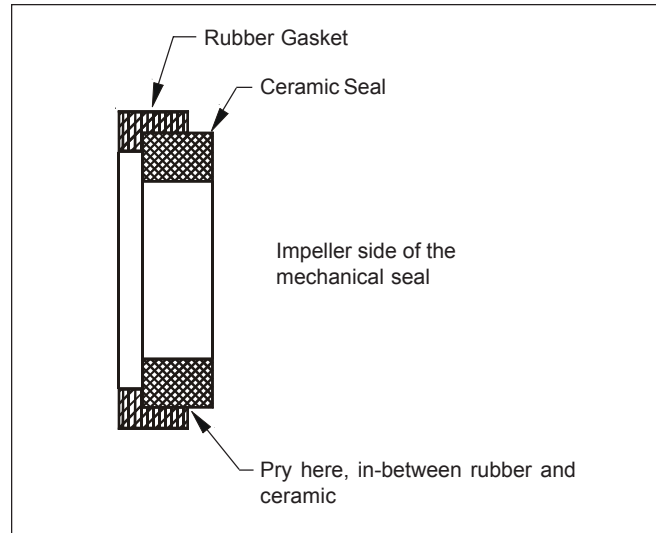

Figure 5. Mechanical Seal Replacement

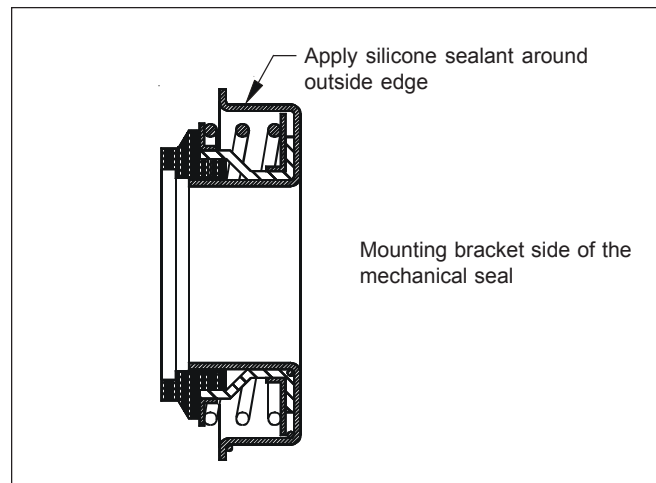

Figure 6. Mechanical Seal Replacement

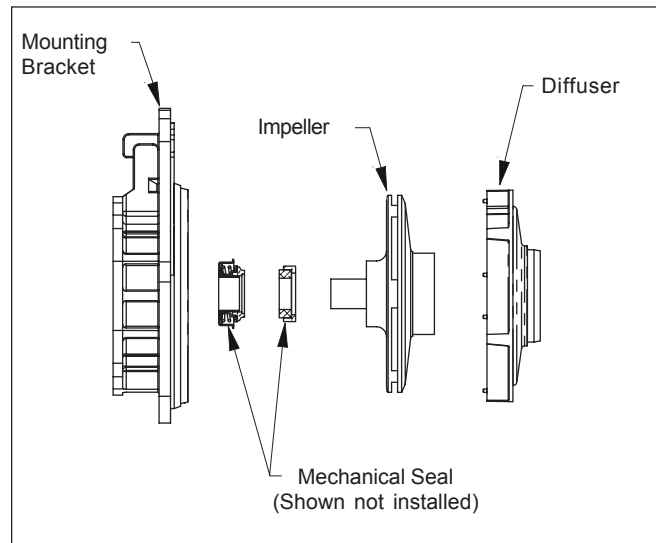

Figure 7. Mechanical Seal Replacement

9.5 Motor Replacement

1. Have a qualified service technician or electrician properly disconnect the electrical wiring at the pump motor.
2. Follow steps 1-7 of section 9.2, "Removing the Impeller."
3. Remove the four (4) bolts holding the mounting bracket to the motor. Before removing the bracket, note the alignment of the mounting bracket to the motor (See Fig. 3).
4. Replace the motor with an identical make and model.
5. Replace the four (4) bolts holding the mounting bracket to the motor.
6. Follow steps 1 thru 15 of section 9.3, "Replacing the Impeller."
7. Have a qualified service technician or electrician properly connect the electrical wiring at the pump motor.

Note: It is recommended that the mechanical seals be replaced at the same time the motor is replaced.

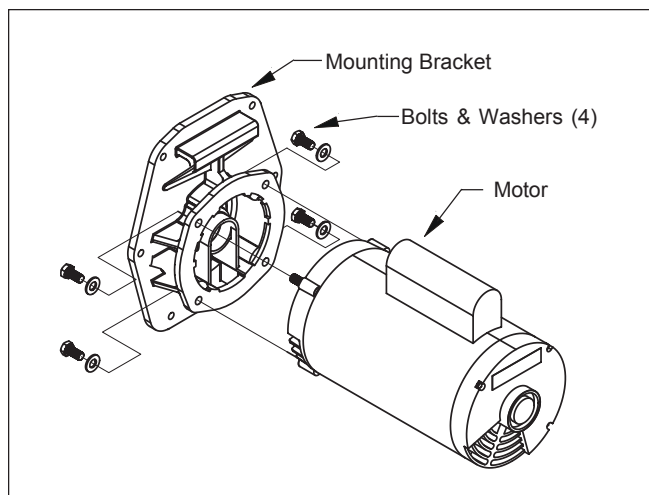

Figure 8. Mounting Bracket Assembly

SECTION 10.

Exploded View & Replacement Kit

Part Numbers

To order or purchase parts for Jandy pumps, contact your nearest Jandy dealer. If they cannot supply you with what you need, contact Jandy customer service at 800.227.1442 or send an e-mail message to info@jandy.com.

10.1 Jandy® JHP & JHPU Pump Series

Key No.	Description	Size (HP)	ORDER PART NO:
1	Motor, single-speed JHP/PHP	1.0	R0556102
1	Motor, single-speed JHP/PHP	1.5	R0556103
1	Motor, single-speed JHP/PHP	2.0	R0556104
1	Motor, single-speed JHP/PHP	3.0	R0556105
1	Motor, single-speed JHPU/PHPU	1.0	R0556101
1	Motor, single-speed JHPU/PHPU	1.5	R0556102
1	Motor, single-speed JHPU/PHPU	2.0	R0556103
1	Motor, single-speed JHPU/PHPU	2.5	R0556104
1	Motor, 2-speed JHPU/PHPU	2.0	R0556203
1	Motor, 2-speed JHPU/PHPU	2.5	R0556204
2	Mounting Bracket JHP/PHP Series	All	R0556000
3	Impeller, JHP/PHP	1.0	R0555802
3	Impeller, JHP/PHP	1.5	R0555803
3	Impeller, JHP/PHP	2.0	R0555804
3	Impeller, JHP	3.0	R0555805
3	Impeller, JHPU/PHPU	1.0	R0555801
3	Impeller, JHPU/PHPU	1.5	R0555802
3	Impeller, JHPU/PHPU	2.0	R0555803
3	Impeller, JHPU/PHPU	2.5	R0555804
3	Impeller, 2-speed JHPU/PHPU	2.0	R0555803
3	Impeller, 2-speed JHPU/PHPU	2.5	R0555804
4	Diffuser	1.0-2.5	R0555701
4	Diffuser	3.0	R0555705
5	Mechanical Seal	All	R0338200
6	Body, Pump JHP Series	All	R0555600
7	Mounting Foot Assy. JHP/PHP	All	R0556000
8	Pot Lid w/clamp ring JHP Series	All	R0555300
9	Pot Basket JHP Series	All	R0555500
10	Gasket, Body JHP Series	All	R0555900
11	O-ring, Diffuser JHP/PHP Series	.75-2.5	R0558701
11	O-ring, Diffuser JHP/PHP Series	3.0	R0558705
12	O-ring, Pot Lid JHP Series	All	R0555400
13	Hardware Set, Diffuser Mntg. ¹ JHP/PHP Series	1.0-2.5	R0555201
14	Drain Plugs (2) JHP/PHP Series	All	R0559500
15	Hardware Set (2), Foot Mntg. ¹	All	R0339200
16	Hardware Set (6), Bracket Mntg. ¹	All	R0339300
17	Hardware Set (4) Motor Mntg. ¹	All	R0339400
18	Coupling Nut Set (2") JHP Series	1.0-2.5	R0556300
18	Coupling Nut Set (2½"-3") JHP Series	3.0	R0559600
19	O-ring, (2), Coupling Set JHP/PHP Series	All	R0339600
20	Cone w/O-ring JHP/PHP Series	.75-2.5	R0559400
20	Cone w/O-ring JHP/PHP Series	3.0	R0559300
	O-ring Set, Complete (7) JHP/PHP Series	All	R0556500
	Hardware Set, Complete JHP/PHP Series	All	R0556600

NOTES:

1. All hardware sets contain all pieces necessary for assembly.

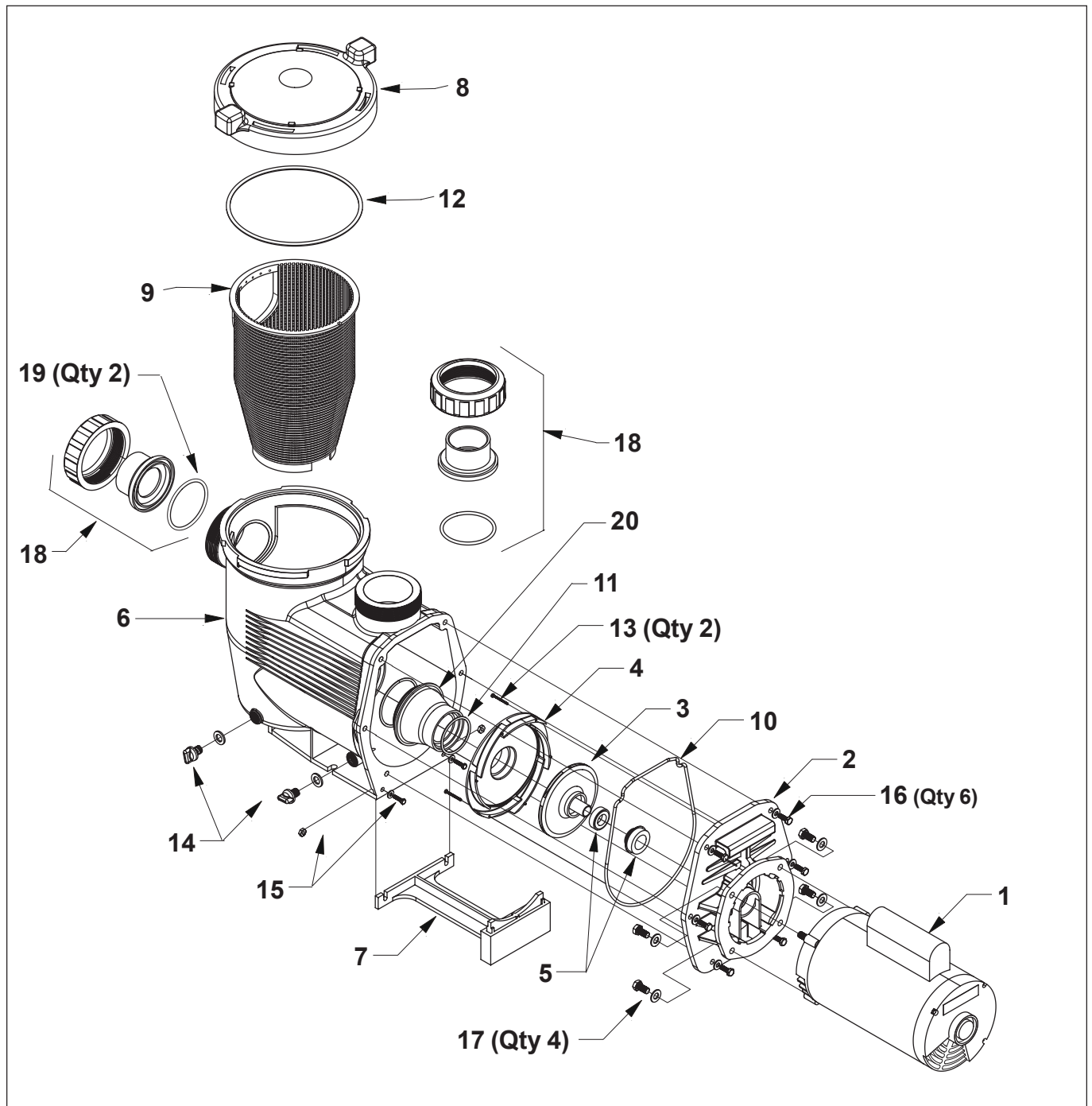
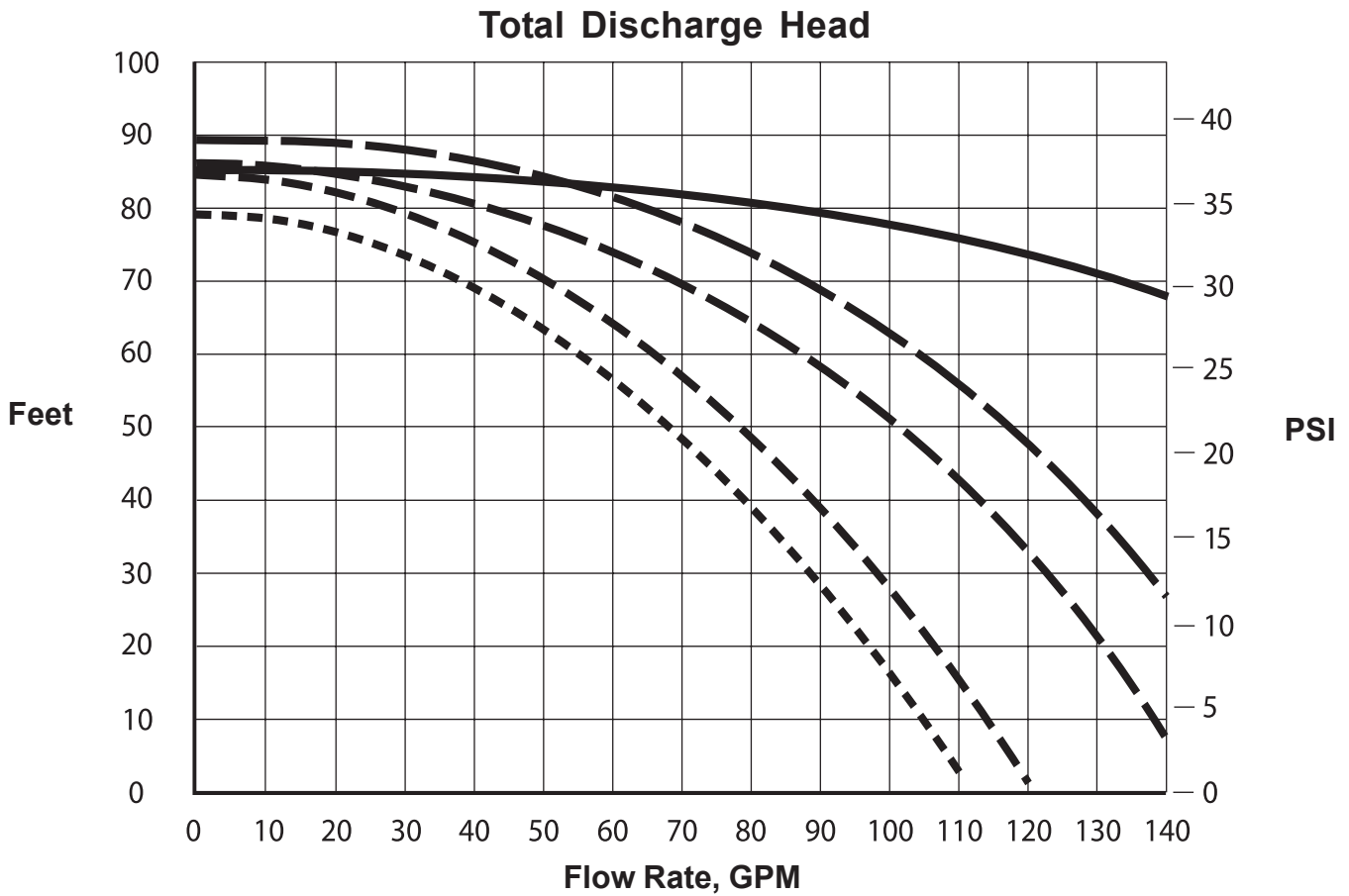

Figure 9. JHP & JHPU Exploded View

SECTION 11. Pump Curves

11.1 Jandy® JHP & JHPU Pump Curves

- JHPU1.0
- JHP1.0/JHPU1.5
- JHP1.5/JHPU2.0/JHP1.5-2/JHPU2.0-2
- JHP2.0/JHPU2.5/JHPU2.5-2
- JHP3.0



SECTION 12. Pump Dimensions

12.1 Jandy® JHP & JHPU Pump Dimensions

MODEL NO.	HP	VOLTAGE	PIPE SIZE	CARTON WEIGHT	OVERALL LENGTH (A)	
					Franklin	Century
JHP1.0	1.0	115/230	2"	45lbs.	29 ¹ / ₄ "	29 ³ / ₄ "
JHP1.5	1.5	115/230	2"	50lbs.	30"	31"
JHP2.0	2.0	230	2"	57lbs.	31 ³ / ₈ "	30 ¹ / ₂ "
JHP3.0	3.0	230	2 ¹ / ₂ "	68lbs.	32 ³ / ₈ "	31 ¹ / ₂ "

MODEL NO.	HP	VOLTAGE	PIPE SIZE	CARTON WEIGHT	OVERALL LENGTH (A)	
					Franklin	Century
JHPU1.0	1.0	115/230	2"	45lbs.	28 ⁷ / ₈ "	29 ¹ / ₄ "
JHPU1.5	1.5	115/230	2"	50lbs.	29 ¹ / ₄ "	29 ³ / ₄ "
JHPU2.0	2.0	115/230	2"	57lbs.	30"	31"
JHPU2.5	2.5	230	2 ¹ / ₂ "	64lbs.	31 ³ / ₈ "	30 ¹ / ₂ "
JHPU2.0-2	2.0	115/230	2"	57lbs.	31 ¹ / ₄ "	30 ¹ / ₂ "
JHPU2.5-2	2.5	115/230	2 ¹ / ₂ "	64lbs.	30 ³ / ₈ "	31"

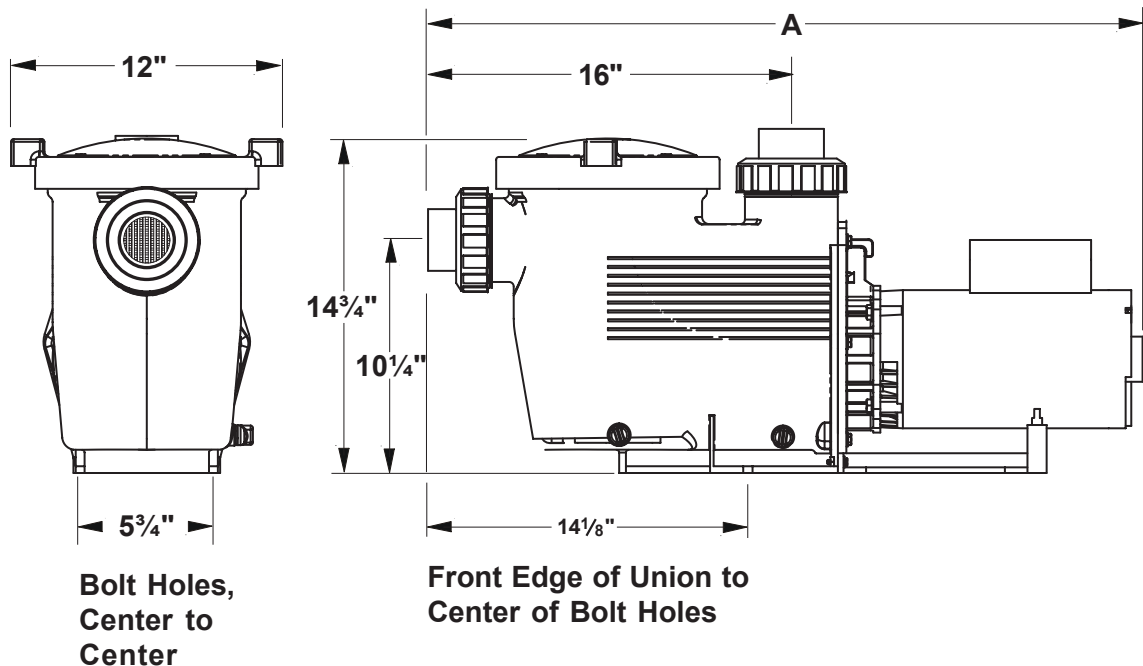

Notes:

LIMITED WARRANTY

Thank you for purchasing Jandy® pool and spa products. Water Pik Technologies (manufacturer of Jandy products, including Laars® pool and spa heaters) warrants all parts to be free from manufacturing defects in materials and workmanship for a period of one year from the date of retail purchase, with the following exceptions:

- AquaLink® RS units installed with Jandy Surge Protection Kits will be covered for two years.
- NeverLube® valves are warranted for the life of pool and/or spa on which they were originally installed.

This warranty is limited to the first retail purchaser, is not transferable, and does not apply to products that have been moved from their original installation sites. The liability of Water Pik Technologies shall not exceed the repair or replacement of defective parts and does not include any costs for labor to remove and reinstall the defective part, transportation to or from the factory, and any other materials required to make the repair. This warranty does not cover failures or malfunctions resulting from the following:

1. Failure to properly install, operate or maintain the product(s) in accordance with our published Installation, Operation and Maintenance Manuals provided with the product(s).
2. The workmanship of any installer of the product(s).
3. Not maintaining a proper chemical balance in your pool and/or spa [pH level between 7.2 and 7.8, Total Alkalinity (TA) between 80 to 120 ppm, Total Dissolved Solids (TDS) less than 2000].
4. Abuse, alteration, accident, fire, flood, lightning, rodents, insects, negligence or acts of God.
5. Scaling, freezing, or other conditions causing inadequate water circulation.
6. Operating the product(s) at water flow rates outside the published minimum and maximum specifications.
7. Use of non-factory authorized parts or accessories in conjunction with the product(s).
8. Chemical contamination of combustion air or improper use of sanitizing chemicals, such as introducing sanitizing chemicals upstream of the heater and cleaner hose or through the skimmer.
9. Overheating, incorrect wire runs; improper electrical supply; collateral damage caused by failure of O-Rings, DE grids, or cartridge elements; or damage caused by running the pump with insufficient quantities of water.

LIMITATION OF LIABILITY:

This is the only warranty given by Water Pik Technologies. No one is authorized to make any other warranties on Water Pik Technologies' behalf. **THIS WARRANTY IS IN LIEU OF ALL OTHER WARRANTIES, EXPRESSED OR IMPLIED, INCLUDING BUT NOT LIMITED TO ANY IMPLIED WARRANTIES OF FITNESS FOR A PARTICULAR PURPOSE AND MERCHANTABILITY. WATER PIK TECHNOLOGIES EXPRESSLY DISCLAIMS AND EXCLUDES ANY LIABILITY FOR CONSEQUENTIAL, INCIDENTAL, INDIRECT OR PUNITIVE DAMAGES FOR BREACH OF ANY EXPRESSED OR IMPLIED WARRANTY.** This warranty gives you specific legal rights. You may also have other rights which vary by state or province.

WARRANTY CLAIMS:

For prompt warranty consideration, contact your dealer and provide the following information: proof of purchase, model number, serial number and date of installation. The installer will contact the factory for instructions regarding the claim and to determine the location of the nearest designated service center. If the dealer is not available, you can locate a service center in your area by visiting www.jandy.com or by calling our technical support department at (707) 776-8200 extension 260. All returned parts must have a Returned Material Authorization number to be evaluated under the terms of this warranty.